

25,000 and 35,000
Btu/hr. Model

50,000
Btu/hr. Model



Top-Vent Gravity Wall Furnace

Model Numbers:

2509622; 2539622; 2559622; 3509622; 3539622; 3559622;
5009622; 5039622; 5059622

FOR USE WITH NATURAL GAS ONLY

Model Numbers:

2509621; 2539621; 2559621; 3509621; 3539621; 3559621;
5009621; 5039621; 5059621

FOR USE WITH PROPANE GAS ONLY

READ THIS OWNER'S MANUAL CAREFULLY BEFORE YOU
INSTALL YOUR NEW WILLIAMS WALL FURNACE.

WARNING: If the information in these instructions is not followed exactly, a fire or explosion may result causing property damage, personal injury or loss of life.

- Do not store or use gasoline or other flammable vapors and liquids in the vicinity of this or any other appliance.
- **WHAT TO DO IF YOU SMELL GAS:**
 - Open all windows.
 - Do not try to light any appliance.
 - Do not touch any electrical switch; do not use any phone or cell phone in your building.
 - Extinguish any open flame.
 - Immediately call your gas supplier from a neighbor's phone. Follow the gas supplier's instructions.
 - If you cannot reach the gas supplier, call the fire department.
- Installation and service must be performed by a qualified installer, service agency or the gas supplier.

WARNING: Improper installation, adjustment, alteration, service or maintenance can cause injury or property damage. Refer to this manual. For assistance or for additional information consult a qualified installer, service agency or the gas supplier.

Warranty

The manufacturer, Williams Furnace Co., warrants this wall furnace or heater to the original purchaser under the following conditions:

LIMITED ONE-YEAR WARRANTY

1. Any part thereof which proves to be defective in material or workmanship within one year from date of original purchase for use will be replaced at the Manufacturer's option, FOB to its factory.
2. No liability is assumed by the Manufacturer for removal or installation labor costs, nor for freight or delivery charges.

LIMITED EXTENDED WARRANTY

1. In addition to the above limited one-year warranty on the complete unit, any combustion chamber which burns out or rusts under normal installation, use and service conditions during a period of nine years following expiration of the one-year warranty period will be exchanged for a like or functionally similar part.
2. No liability is assumed by the Manufacturer for removal or installation labor costs, nor for freight or delivery charges.

LIMITATIONS

1. THIS LIMITED WARRANTY IS THE ONLY WARRANTY MADE BY THE MANUFACTURER, IMPLIED WARRANTIES OF MERCHANTABILITY OR FITNESS FOR ANY PARTICULAR PURPOSE ARE LIMITED TO THE SAME ONE YEAR TERM AS THE EXPRESS WARRANTY. UNDER NO CIRCUMSTANCES SHALL THE MANUFACTURER BE LIABLE FOR INCIDENTAL, CONSEQUENTIAL, SPECIAL OR CONTINGENT DAMAGES OR EXPENSES ARISING DIRECTLY OR INDIRECTLY FROM ANY DEFECT IN THE PRODUCT OR ANY COMPONENT OR FROM THE USE THEREOF. THE REMEDIES SET FORTH HEREIN ARE THE EXCLUSIVE REMEDIES AVAILABLE TO THE USER AND ARE IN LIEU OF ALL OTHER REMEDIES.

Some states do not allow limitation on how long an implied warranty lasts, and some states do not allow the exclusion or limitation of incidental or consequential damages, so the above limitations or exclusions may not apply to you.

2. This warranty does not include any charge for labor or installation.
3. This warranty does not extend to painted surfaces or to damage or defects resulting from accident, alteration, misuses or abuse or improper installation.
4. This warranty does not cover claims which do not involve defective workmanship or materials.

DUTIES OF THE CONSUMER

1. The heating equipment must be installed by a qualified installer and operated in accordance with the installation and homeowner's instructions furnished with the equipment.
2. Any travel, diagnostic costs, service labor, and labor to repair the defective unit will be the responsibility of the owner.
3. A bill of sale, cancelled check, payment record or permit should be kept to verify purchase date to establish the warranty period.
4. Have the installer enter the requested information in the space below.

GENERAL

1. The manufacturer neither assumes nor authorizes any person to assume for it any other obligation or liability in connection with said equipment.
2. Service under this warranty should be obtained by contacting your dealer. Provide the dealer with the model number, serial number, and purchase date verification.
3. If, within a reasonable time after contacting your dealer, satisfactory service has not been received, contact: Customer Service Department, 250 West Laurel Street, Colton, CA 92324 for assistance.
4. THIS WARRANTY GIVES YOU SPECIFIC LEGAL RIGHTS AND YOU MAY ALSO HAVE OTHER RIGHTS WHICH VARY FROM STATE TO STATE.

Installation Record

Model No. _____ Serial No. _____

Original Purchaser _____

Address _____

City and State _____ Zip _____

Dealer _____

Address _____

City and State _____ Zip _____

Installation Date _____ Name _____ Signature _____

(Dealer or authorized representative who certifies that this appliance is installed in accordance with Manufacturer's instructions and local codes.)

Contents

| | |
|---|-------|
| Your Williams Warranty | 2 |
| Installation Record | 2 |
| Table of Contents | 3 |
| Safety Rules | 4 |
| Introduction | 5 |
| Basic Materials Needed | 5 |
| Basic Tools Needed | 5 |
| Optional Accessories | 5 |
| Installing Your Wall Furnace | 6 |
| Locating Wall Furnace and Thermostat | 6-7 |
| Combustion & Ventilation Air | 7-9 |
| Installation | |
| Recessed Mount Installation | 10-11 |
| Surface Mount Installation | 12-13 |
| Vent Installation | 14 |
| Attaching Your Furnace | 15-16 |
| Gas Supply and Piping | 16-18 |
| Front Panel Installation | 18 |
| Thermostat Installation | 19 |
| Start Up Procedure | 20-21 |
| Stay Safe | 22-23 |
| Operating Your Furnace | 22-23 |
| How to Care for Your Furnace | 24-25 |
| Installing Your Blower Accessory | 25-26 |
| Blower Accessory Replacement Parts | 27-28 |
| Installing Your Motorized Rear Outlet Accessory | 29-30 |
| Motorized Rear Outlet Replacement Parts | 31-32 |
| Furnace Replacement Parts | 32-37 |
| Troubleshooting Chart | 38-39 |
| Service Hints | 40 |

Quick Reference: Here's how to...

| | |
|--|-------|
| Installing Your Furnace | 6-20 |
| Recessed Mount, Surface Mount, and Vent Installation are explained starting on page 6. | |
| Operating Your Furnace | 22-23 |
| Igniting your furnace for the first time. | |
| Caring for Your Furnace | 24-25 |
| Learn how to keep your new Williams Furnace operating. | |

Safety Rules

WARNING: Read these rules and the instructions carefully. Failure to follow these rules and instructions could cause a malfunction of the furnace. This could result in death, serious bodily injury and/or property damage.

INSTALLATION MUST CONFORM TO LOCAL CODES. IN THE ABSENCE OF LOCAL CODES, INSTALLATION MUST CONFORM TO THE NATIONAL FUEL GAS CODE, ANSI Z223.1. THE APPLIANCE, WHEN INSTALLED MUST BE ELECTRICALLY CONNECTED AND GROUNDED IN ACCORDANCE WITH LOCAL CODES OR, IN THE ABSENCE OF LOCAL CODES, WITH THE CURRENT NATIONAL ELECTRICAL CODE ANSI/NFPA NO. 70.

IN CANADA: Installation must conform to local codes or, in the absence of local codes, the current CAN/CGA B149 Installation code.

The appliance, when installed, must be grounded in accordance with local codes, with the current CSA C22.1 Canadian Electrical Code.

Reference is made in this manual regarding gas type as L.P.G. Be advised that L.P.G. is not available in Canada; refer to Propane/L.P. Gas.

WARNING: Do not use this furnace if any part has been under water. Immediately call a qualified service technician to inspect the furnace and to replace any part of the control system and any gas control which has been under water.

1. Use only manufacturer's replacement parts. Use of any other parts could cause injury or death.
2. DO NOT install the furnace where it could be isolated by closing doors to the heated space.
3. DO NOT install these furnaces in a travel trailer, recreational vehicle or mobile home.
4. MAINTAIN all clearances specified in section "Locating Wall Furnace and Thermostat" and "Vent Installation."
5. BE SURE the furnace is for type of gas being used. Check the nameplate by the gas valve in the lower cabinet. Do not change it to use other gases without the proper manufacturer's gas conversion kit.
6. For natural gas, the minimum inlet gas supply pressure for the purpose of input adjustment is 5" water column. The maximum inlet gas supply pressure is 7" water column. For L.P. gas, the minimum inlet gas supply pressure for the purpose of input adjustment is 11" water column. The maximum inlet gas supply pressure is 13" water column.
7. Any safety screen, guard or parts removed for servicing this appliance must be replaced prior to operating the appliance to avoid property damage, bodily injury or death.

8. Vent the furnace directly to the outdoors, so that harmful gases will not collect inside the building. Follow the venting instructions for your type installation exactly. Use only the type and size of vent pipe and fittings specified.
9. Provide for adequate combustion and ventilation air. See page 7. The flow of this air to the furnace must not be blocked.
10. NEVER vent flue gases into another room, a fireplace or any space inside a building. This could cause property damage, bodily injury or death.
11. NEVER test for gas leaks with an open flame. Use a soap solution to check all gas connections. This will avoid the possibility of fire or explosions.
12. ALLOW furnace to cool before servicing. Always shut off electricity and gas to furnace when working on it. This will prevent any electrical shocks or burns.
13. DUE TO HIGH TEMPERATURES, locate the furnace out of traffic and away from furniture and draperies.
14. ALERT children and adults to the hazards of high surface temperatures and warn them to keep away to avoid burns or clothing ignition.
15. CAREFULLY supervise young children when they are in the same room with the furnace.
16. DO NOT place clothing or other flammable material on or near furnace.
17. INSTALLATION and REPAIR must be done by a qualified service person. The appliance should be inspected before use and at least annually by a professional service person. More frequent cleaning may be required due to excessive lint from carpeting, bedding material, etc. It is imperative that control compartments, burners and circulating air passages be kept clean.
18. BEFORE INSTALLING: To avoid electrical shock, turn off electrical circuits that pass through the wall where you are going to install the furnace.
19. BE AWARE of good safety practices by wearing personal protective equipment such as gloves and safety glasses to avoid being injured by sharp metal edges in or around the furnace while cutting or drilling holes in wood and/or sheet metal.
20. CAUTION: Label all wires prior to disconnection when servicing controls.
21. DO NOT store or use gasoline or other flammable liquids or vapors near the furnace.

WARNING: Do not install any of these furnaces (Natural or L.P. Gas) in mobile homes, trailers or recreational vehicles.

Introduction

The following steps are all needed for proper installation and safe operation of your furnace. If you have any doubts as to any requirements, check with local authorities. Obtain professional help where needed. All of the checks and adjustments in the Start-Up Procedures are vital to the proper and safe operation of the furnace. Please read the instructions before you install and use your furnace. This will help you obtain the full value from this furnace. It could also help you avoid needless service costs if the answer to the problem is found within this instruction manual.

Always consult your local heating or plumbing inspector, building department or gas utility company regarding regulations codes or ordinances which apply to the installation of a vented wall furnace.

Check the furnace nameplate, located in the burner compartment, to make sure your furnace is equipped to operate on the type of gas available (either natural or L.P. gas). DO NOT convert the furnace from natural gas to L.P. gas or from L.P. gas to natural gas without the proper manufacturer's gas conversion kit.

Combustion air is drawn in from the room where the furnace is located and is vented out of the top of the furnace vertically through vent piping in the stud space to a roof vent top. Vent material is not supplied with the furnace.

This furnace is equipped with a vent safety shutoff system designed to protect against improper venting of combustion products. Operation of this wall furnace when not connected to a properly installed and maintained venting system or tampering with the vent safety shutoff system can result in carbon monoxide (CO) poisoning and possible death.

The efficiency rating of this furnace is a product thermal efficiency rating determined under continuous operating conditions and was determined independent of any installed system.

Basic Materials Needed

Pipe and fittings to make gas connections to the furnace.

Pipe Joint Compound resistant to L.P. Gases.

Vertical venting materials. See page 14, Figure 8.

Electrical wiring supplies as needed. Minimum wire size is #14 gauge copper.

Basic Tools Needed

Hand drill or properly grounded electric drill

Hammer

Expansion bit 1/2" to 1-5/8" or 1/2" and 1-1/2" blade bits

Stud Locator or small finishing nails

1/8" and 3/16" drill bit (metal)

Tin Snips

6 ft. folding rule or tape measure

8" adjustable wrench

Screwdriver (medium blade)

12" adjustable wrench

Screwdriver (Phillips head)

Two, 10" or 12" pipe wrenches

Pliers (wire cutting)

Gloves and safety glasses

Helpful Installation Information

The following booklets will help you in making the installation:

ANSI/NFPA 70, or current edition "National Electrical Code". In Canada: CSA C22.1 Canadian Electrical Code.

American National Standard Z223.1 or current edition of the "National Fuel Gas Code."

Obtain from the American National Standard Institute, Inc., 1430 Broadway, New York, NY 10018. In Canada, CAN/CGA B149.

Optional Accessories

Blower Accessories 2901, 2907 - May be used on all models and mounts on top of a furnace. This blower increases circulation of warm air through the heated space. A 115V outlet adjacent to the furnace is required.

Trim Strip Kit 4701 - Provides a finished edge for sides of the wall furnace.

Free Standing Accessory 4901 - May be used with single-sided models. This accessory allows the furnace to be mounted on the surface of a wall.

Vent Adapter Kit 9902, 9910 - Optional vent adapter, typically used when the furnace is vented into a properly lined chimney.

Rear Outlet Registers 6901, 6919, 6920 - May be used with single-sided models when recessed into a standard 2x4 inch interior stud partition. This accessory directs some of the heated air into the room opposite the one in which the furnace is installed.

Oval B/W Vent Kit 9901 - This U.L. listed B/W vent kit contains four feet of oval, double-walled vent pipe, plate spacers and base or hold-down plate that starts the venting from the top of furnace. See Vent Installation on page 14 for additional items you will need.

Plaster Ground Kit 6905 - Used for 6901 or 6919 Rear Outlet Registers.

Gas Conversion Kits - See page 16.

Installing Your Furnace

The following steps are needed for proper installation and safe operation of your furnace. If you have any doubts as to any requirements, obtain professional help. Remember to ALWAYS consult your local heating or plumbing inspector, building department or gas utility company regarding regulations, codes, or ordinances which apply to the installation and location of a vented wall furnace.

IMPORTANT

For satisfactory and trouble-free operation, be sure to:

1. Locate the furnace properly within the space to be heated.

Locating Wall Furnace & Thermostat

The furnace is installed between 2x4 inch wall studs spaced on 16-inch centers or a stud space that can be framed in to 16-inches.

Consider the following points before attempting to install the furnace:

CAUTION: Do not make cutouts in the wall or ceiling before checking in the attic for ceiling joist locations and proposed venting.

1. Locate the furnace near the center of the space to be heated for good air circulation. Do not put it behind a door or draperies. Do not install the furnace where it could be isolated by closing doors to the heated space. Do not locate the furnace where a door could swing over the front panel or where circulation could be retarded by furniture or cabinets.
2. Check the minimum spacing needs as shown in Figure 1.
3. The top of the furnace must be at least 16-inches from the ceiling.
4. When the furnace is properly installed with legs resting on the floor plate, it sets the dimension from the face panel to the bare floor. (Approximately 2½-inches depending on the thickness of floor plate).
5. A protective barrier (metal or wood), cut to match the width and depth of the furnace, should be used to cover over any floor coverings such as carpet or vinyl under the furnace. At no time should the dimension from the bottom of the face panel to the protective barrier be less than 1½-inches.
6. In the space to be heated, the side of the furnace may be as close as 4-inches to an intersecting wall. The recessed portion may have 0-inches clearance to combustible material.
7. Select a location that will provide adequate accessibility clearance for servicing and proper operation.

2. Install the furnace in accordance with local codes or ordinances and instructions provided. In the absence of local codes or ordinances, install the furnace to conform with the current edition of the National Fuel Gas Code, NFPA 54, ANSI Z223.1/Canadian Installation Code, CAN/CGA B149.
3. Maintain minimum clearances: Floor 2½-inches, ceiling 16-inches, side wall 4-inches.
4. Provide enough combustion and ventilation air.

8. After picking a location, inspect the wall, floor, attic and roof areas. Make sure there are no pipes, wiring, bracing, etc., that will interfere with furnace or vent installation. If required, move them or pick a new installation location.
9. Be sure that gas piping and electrical wiring can be brought to the location. Electrical wiring is required for optional blower accessory.
10. If installing the thermostat on the wall, locate the thermostat approximately 5-feet above the floor on an inside wall where it will sense the average room temperature.

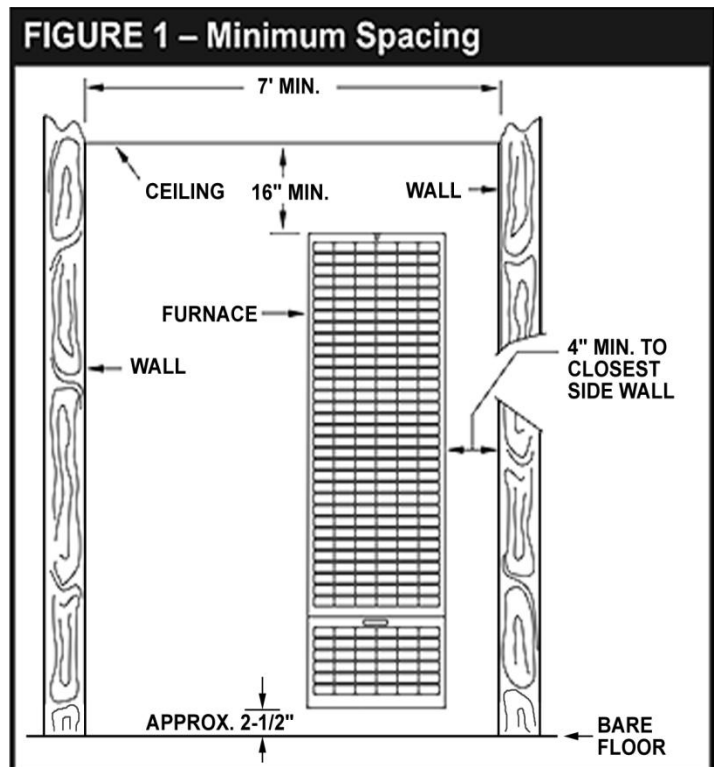

Installing Your Furnace

Locating Wall Furnace & Thermostat (continued)

The thermostat should be sensing average room temperature; avoid the following:

HOT SPOTS:

Concealed pipes or ducts
Fireplaces
Registers
TV sets
Radios
Lamps
Direct sunlight
Kitchen

COLD SPOTS:

Concealed pipes or ducts
Stairwells – drafts
Doors – drafts
Unheated rooms on other side of wall

DEAD SPOTS

Behind doors
Corners and alcoves

After picking a location that meets the requirements, check the walls, attic and roof to make sure there are no obstructions such as pipes, electrical wiring, etc., which could interfere with the installation of the furnace or vent pipe. If required, move them or pick a new location.

WARNING: Danger of property damage, bodily injury or loss of life. Do not install the furnace in any area where oxygen is in use.

Combustion & Ventilation Air

WARNING: Danger of property damage, bodily injury or loss of life. The furnace and any other fuel-burning appliances must be provided with enough fresh air for proper combustion and ventilation of flue gases. Most homes will require that outside air be supplied into the heated area.

The high cost of energy for home heating has brought about new materials and methods used to construct or remodel most current homes. The improved construction and additional insulation has reduced the heat loss and made these homes much tighter around windows and doors so that infiltrated air is minimal. This creates a problem to supply combustion and ventilation air for gas-fired or other fuel burning appliances. Any use of appliances that pull air out of the house (clothes dryers, exhaust fans, fireplaces, etc.) increases this problem and appliances could be starving for air.

The combination of a tight energy efficient home with the use of exhaust fans, fireplaces, clothes dryers, and gas appliances result in more and more air being drawn from the house until fresh air may be sucked back into the house down a furnace flue or fireplace chimney. Carbon monoxide can be the result. Carbon monoxide (CO) is a colorless, odorless gas produced when fuel is not burned completely or when the flame does not receive sufficient oxygen. Automobiles, charcoal, wood fires and improperly vented or air-starved coal, oil and gas furnaces or other appliances can produce carbon monoxide.

Do not install furnace in the same room or near a wood solid fuel burning fireplace.

BE AWARE OF THESE AIR-STARVATION SIGNALS:

1. Headaches, nausea, dizziness.
2. Excessive humidity shown by heavily frosted windows or a moist "clammy" sensation.
3. Fireplace smoke fills the room or will not draw.
4. Furnace flue backs up.

AIR REQUIREMENTS

The requirements for providing air for combustion and ventilation are listed in the National Fuel Gas Code NFPA 54/ANSI Z223.1 (in Canada: CAN/CGA B149). Most homes will require that outside air be supplied to the heated area by means of ventilation grilles or ducts connecting directly to the outside or spaces open to the outdoors such as attic or crawl space. The only exception is when the heated area meets the requirements and definitions for an unconfined space with adequate air infiltration.

All air openings and connecting ducts must comply with the following:

If the furnace is installed in an area with another gas appliance(s), the total input rating of all appliances must be considered when determining the free area requirements for combustion and ventilation air openings.

Ducts must have the same cross-sectional area as the free area of the openings to which they connect. The minimum dimension of rectangular air ducts must not be less than 3-inches in length or height.

WARNING: Danger of property damage, bodily injury or loss of life. Even when a house meets requirements for unconfined space with adequate air infiltration, it is recommended that a fresh air intake be installed to lessen the possible dangers from any future changes on the home

Installing Your Furnace

Combustion & Ventilation Air (continued)

LOUVERS / GRILLES AND SCREENS COVERING FREE AREA OPENINGS

If a screen is used to cover the opening(s), it must not be smaller than 1/4-inch mesh. Use the free area of a louver or grille to determine the size opening required to provide the free area specified. If the free area is not known, assume a 20% free area for wood and a 60% free area for metal louvers or grilles.

INFILTRATION AIR

If your furnace is in an open area (unconfined space), the air that leaks through the cracks around doors and windows may be enough for combustion and ventilation air. The doors should not fit tightly. The cracks around windows should not be caulked or weather stripped.

Spillage means air starvation. A fresh air duct or air intake opening must be installed to provide air directly to the furnace or other gas appliances.

If spillage exists or when the furnace is in a building of tight construction where the windows and doors are weather stripped, air for combustion and ventilation must be obtained from outdoors or space open to the outdoors.

To determine if infiltration air is adequate, perform the following checks:

1. Close all doors and windows. If you have a fireplace, start a fire and wait until flames are burning vigorously.
2. Turn on all exhausting devices, i.e., kitchen and bathroom exhaust fans; water heaters (gas and electric).
3. Turn on all vented gas appliances, i.e., heating equipment (includes any room heaters), water heaters.
4. Wait ten (10) minutes for drafts to settle.
5. Check for draft hood spillage at each appliance. Hold a lit match two-inches from the draft opening. (Figure 2).

FIGURE 2 – Draft Hood Spillage

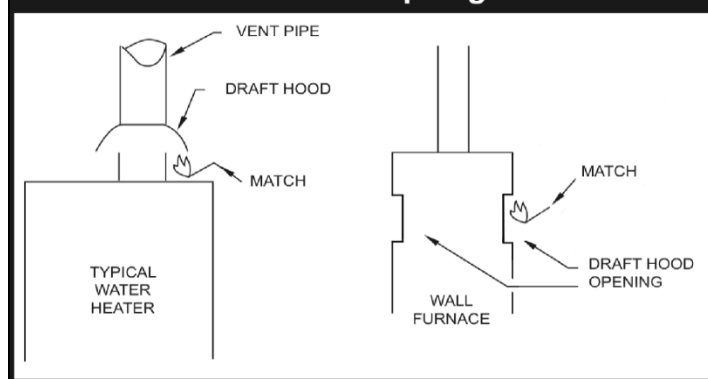

A. No Spillage

If the match flame pulls toward draft hood, this indicates sufficient infiltration air. Return exhausting devices and appliances to the condition you found them.

B. Draft Hood Spills

If there is spillage at a draft hood (match goes out or flame wavers away from draft hood), check for plugged flue connectors and chimneys. Repair blockage and test again.

If you have a fireplace, open a window or door near the fireplace and then check for spillage. If spillage stops, do not use the fireplace without a nearby window or door open until you can supply fresh air by a permanent duct.

If you have kitchen and bathroom exhaust fans, turn them off and check for spillage. If spillage stops, do not use exhaust fans (circuit breakers for fans should be turned off) until you can supply fresh air by a permanent duct.

Provide opening(s) having a total free area of one-square-inch per 4,000 Btu/hr. of the total combined input ratings for all appliances in the area. The required free area is shown in Figure 3. This fresh air opening or duct must terminate at a point not more than one-foot above the floor. It must have at least one-square inch of free area for each 4,000 Btu/hr. of input of all appliances in area.

FIGURE 3 – Free Area

| Free Area in Square inches. Each Opening is Based on One Square inch per 4000 Btu/hr. | | | | |
|---|--------------------------|--|----|----|
| Btu/hr. input | Square inches of Opening | Required Number of Holes Sill or Header Plates | | |
| | | 1-1/2" | 2" | 3" |
| 30,000 | 7.50 | 7 | 4 | 2 |
| 35,000 | 8.75 | 8 | 5 | 2 |
| 40,000 | 10.00 | 9 | 5 | 3 |
| 45,000 | 11.25 | 10 | 6 | 3 |
| 50,000 | 12.50 | 11 | 6 | 3 |
| 60,000 | 15.00 | 13 | 8 | 4 |

Hole Placement - Example

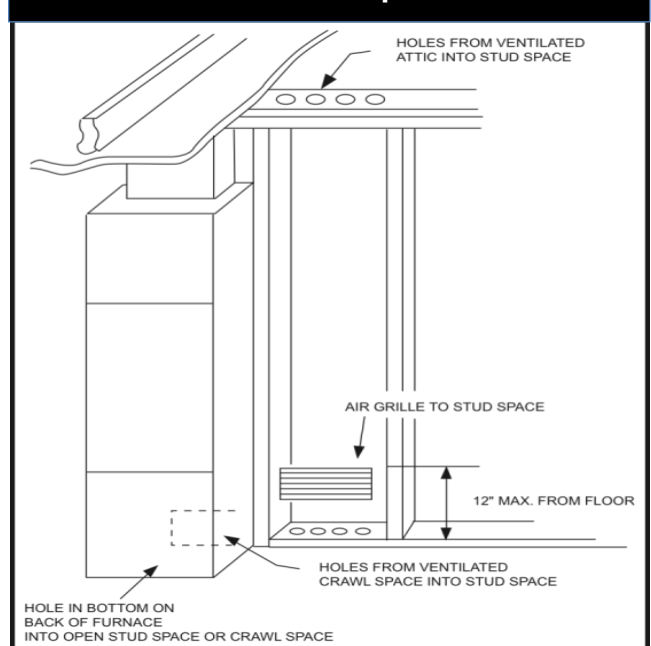

Installing Your Furnace

Combustion & Ventilation Air (continued)

FURNACE LOCATED IN UNCONFINED SPACE

An unconfined space must have a volume of a minimum 50 cubic feet per 1,000 Btu/hr. of the total combined input of all appliances in the area. Adjoining rooms may be included only if there are no doors between the rooms or if special provisions are made such as ventilation grilles installed between connecting rooms. Figure 4 outlines the minimum area in square feet, based on 8-foot ceiling heights for various Btu/hr. input ratings.

FIGURE 4 – Minimum Area

| 4,000 Btu/hr. per Square inch Opening | | Max. Btu/hr. Input | *Unconfined Space Min. Area in Sq. Ft. 8' Ceiling Height |
|---------------------------------------|------------------------------|--------------------|--|
| Round Duct Dia. | Rectangular/Square Duct Size | | |
| 4" | 3" x 3" | 30,000 | 188 |
| 4" | 3" x 3" | 35,000 | 219 |
| 4" | 3" x 4" | 40,000 | 250 |
| 4" | 3" x 4" | 45,000 | 281 |
| 4" | 3" x 5" | 50,000 | 312 |
| 4-1/2" | 3" x 5" | 60,000 | 375 |

*Can be two or more rooms joined by ventilation grilles.

FURNACE LOCATED IN CONFINED SPACE

If a furnace is installed in a confined space, it must be provided with free air for proper combustion and ventilation of flue gases by one of the following methods:

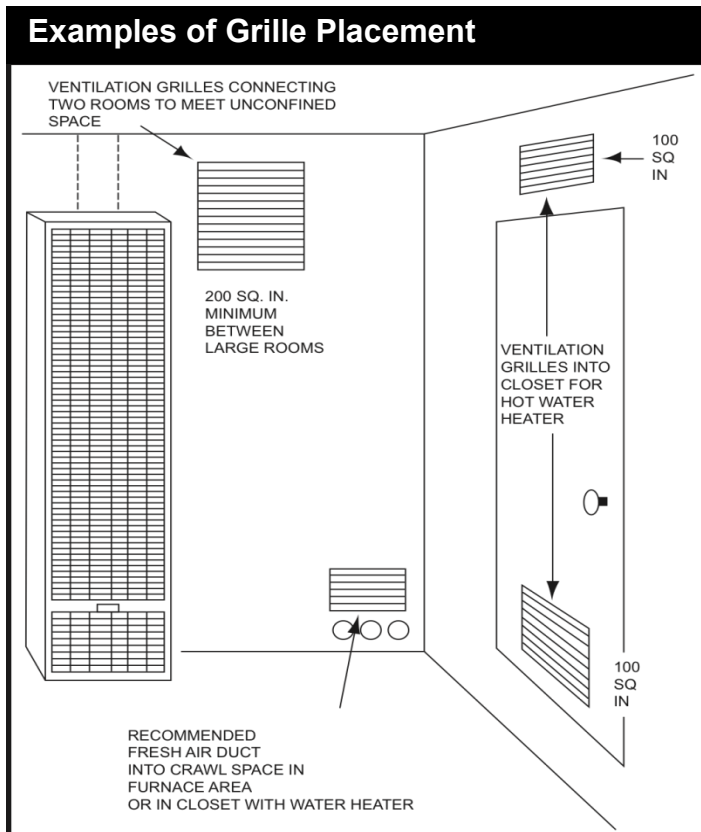

A. Air From Inside the Building

If the confined space adjoins an unconfined space, provide two permanent openings. One within 12-inches of the top and another within 12-inches of the bottom of the room directly connected to the unconfined space. Each opening must have a free area of at least 100-square inches or 1-square inch per 1,000 Btu/hr. of input for all appliances combined.

WARNING: Danger of property damage, bodily injury or death. The adjoining unconfined space must have adequate air infiltration.

B. Air From Outdoors

If confined space does not adjoin an unconfined space, then air must be provided from outdoors or spaces open to the outdoors such as an attic or crawl spaces.

Openings for inlet or outlet air should NOT be made into an attic area if the attic is equipped with a thermostat controlled power vent.

Provide two permanent openings, one within 12-inches of the top and bottom of the room connecting directly to, or by using ducts, with the outdoors or areas open to fresh air.

If the opening connects directly to, or with vertical ducts, the free area of each opening must be at least 1-square inch per 4,000 Btu/hr. of the combined input of all appliances in the area.

If horizontal ducts are used, the free area of each opening must be at least 1-square inch per 2,000 Btu/hr. of the combined input of all appliances in the area.

WARNING: Danger of illness, bodily injury or death. Draft hood spillage, with unobstructed vents, indicates that additional air must be brought into the structure from the outside. Keep a window open (minimum 2-inches) near the appliance until a permanent air duct is installed.

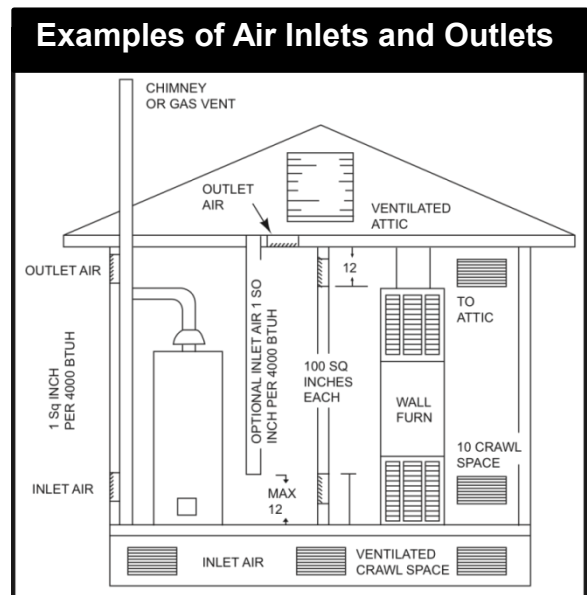

Installing Your Furnace

Recessed Wall Mount Installation

On models 2509621, 2539621, 2559621, 2509622, 2539622, 2559622, 3509621, 3539621, 3559621, 3509622, 3539622, and 3559622, the maximum recess depth from rear of furnace forward is 4½ inches.

FIND THE STUDS AND CEILING JOINTS

Use a stud locator or small finishing nails. Repeatedly drive and remove a nail into the wall in the area of the stud until it is located. Then find the inside edge of the stud. Leave the nail at this location.

The other stud should be about 14½-inches from the one found. Drive finishing nails on the inside of this stud. Draw wall cutout to required size as shown in Figure 5. If wall studs are not on 16-inch centers. See "CLOSE OFF STUD SPACE." (Figure 6).

CUT WALL OPENING

Cut wall opening 14⅜-inches wide and 66⅞-inches high measured from the top of the floor plate. (Figure 5). All corners must be square.

INSTALLATION OF REAR OUTLET REGISTER

The optional rear outlet register may be installed when the furnace is recessed into the wall. In new construction, install the rear outlet plaster ground at the same time you install the header plate. For existing construction, make the necessary cutout and install the plaster ground before you install the furnace. See instructions packed with accessory and Figure 5.

Do not allow wall finish material to project into the furnace recess.

Do not install rear outlet register where grille may be blocked by a door, curtains or any other obstruction.

GAS SUPPLY OPENING

A hole must be drilled for the gas line. Decide whether the gas line will come through the floor or wall. Drill a 1½-inch hole through the floor or wall as needed. (Figure 5).

CAUTION: Be careful not to damage any furnace components while making any alternate hole.

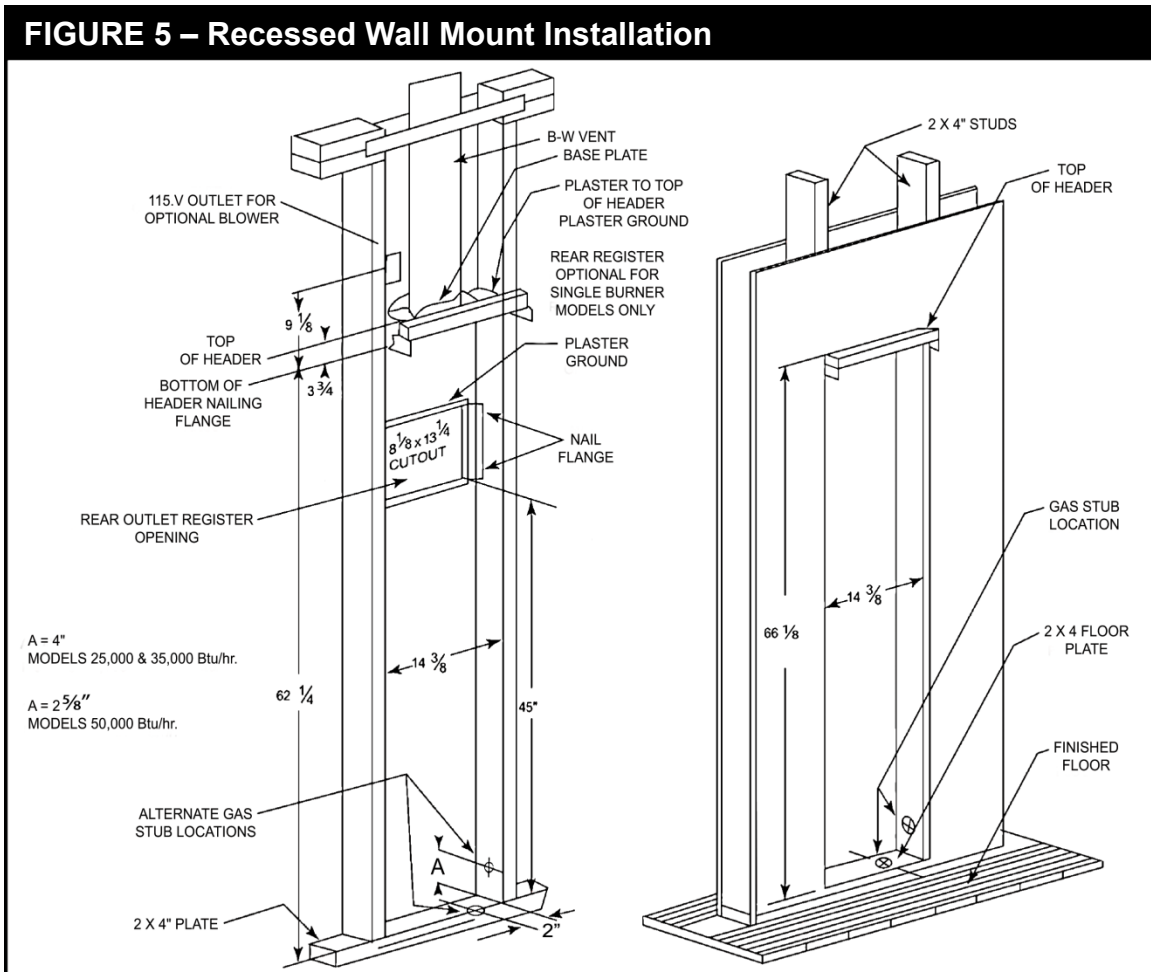

Installing Your Furnace

Recessed Wall Mount Installation (continued)

CLOSE OFF STUD SPACE (If Required)

If studs are not on 16-inch centers, cut the hole for the furnace next to an existing stud and frame in the other side using a 2x4 and spacer blocks as required. (Figure 6).

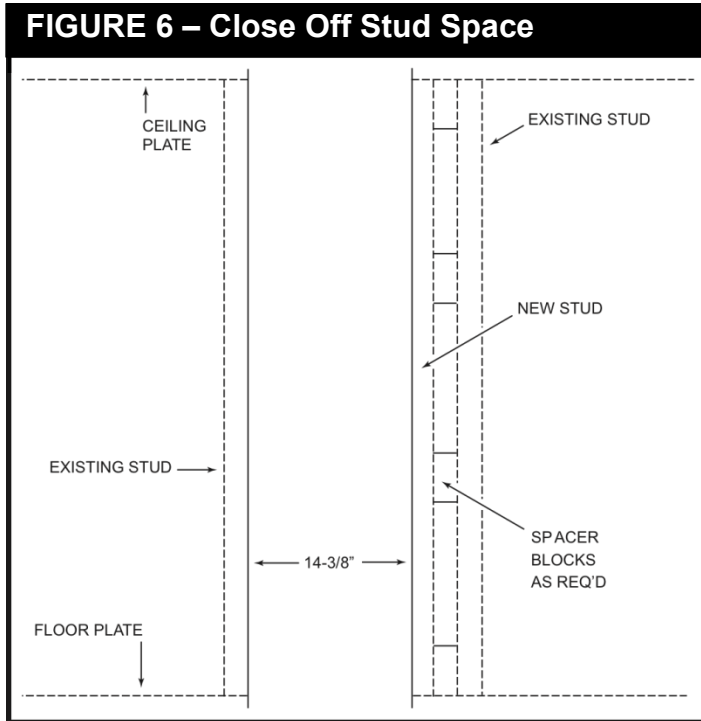

CEILING PLATE OPENING

Cut away the ceiling plate between the studs where the furnace is to be installed. Work from the top in the attic. If there is no access to the top, remove the wall covering between the two wall studs all the way to the ceiling. Work through this opening. Cut out the entire plate so the plate edges will be even with the inner face of the 2x4 studs. (Figure 7).

INSTALL VENT BASE PLATE (HOLD-DOWN PLATE)

Position base plate on top of header plate and fasten with screws. Note: **Hold down plate is not included.**

HEADER PLATE (VENT SUPPORT)

Measure upward 62¼-inches from the top of the floor plate. Place a mark on each stud at this distance. (Figure 5). Place the header plate between the studs with the lower edges even with marks on the studs. Make sure header plate is level.

Locate rear edge of nailing tabs at back of the header. Nail header plate to the 2x4 studs which will center the vent collar in the wall. (Figure 5).

INSTALL CEILING PLATE SPACER

Nail the ceiling plate spacers either across or in between the cut out section of ceiling plate. If nailed between, ends must be bent at 90 degrees. They must be fastened along each long edge of the ceiling plate hole to hold the oval vent pipe in the center of the hole. Ceiling plate spacers preserve structural strength and position oval vent pipe in the center of the cut out opening. **Ceiling plate spacers are not included.** (Figure 7).

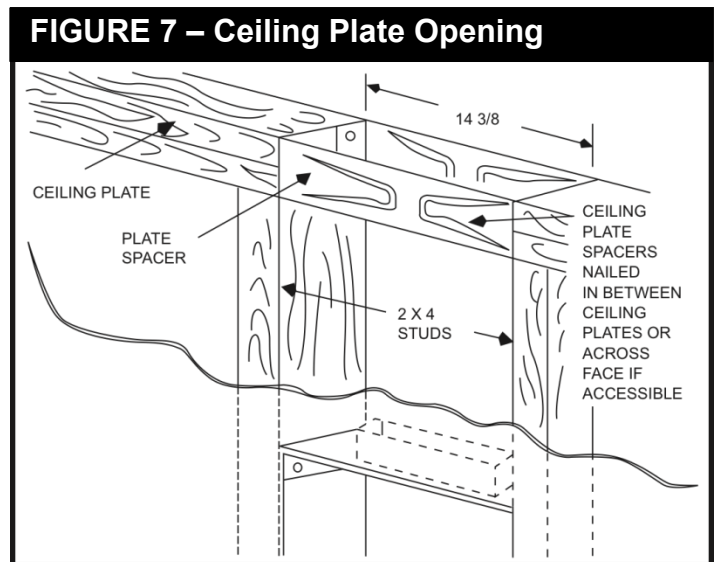

Installing Your Furnace

Surface Mount Installation

The use of the optional Free Standing Accessory No. 4901 allows single-sided furnaces to be surface mounted instead of recessed into a wall. This is ideal for remodeling existing masonry wall construction or when studing is substandard. This kit drastically cuts installation time and eliminates the expense of cutting into the walls and ceiling plates. Be sure this accessory is of the type and design required for the use with your furnace.

NOTE: After picking a location that meets the requirements, check the wall, attic, and roof to make sure there are no obstructions such as pipes, electrical wiring, etc., which could interfere with the installation of the furnace or vent pipe. If required, move them or pick a new location.

FIND THE WALL STUDS OR CEILING JOISTS

Find two studs or joists at the spot where the furnace is to be located. Use a stud locator or small finishing nails. Repeatedly drive and remove a nail into the wall or ceiling in the area of the stud or joist until you find it. Then find the its side and leave the nail there. Drive another nail just on the other side other the same stud or joist.

The inside of the next stud or joist should be about 14½ inches from the first one found. Drive a nail on the inside of this stud or joist.

Using the nails as a guide, draw two lines down the side of the wall from the ceiling to locate the furnace and ceiling hole cutout for venting.

FREE STANDING ACCESSORY ASSEMBLY & INSTALLATION

1. Attach the base plate panel as shown in Figure A to the bottom of the side rails with four (4) # 6, ⅝" screws.
2. Attach the header plate, (included with the furnace), to the side rails using four (4) #8, ⅝" screws. Flanges of the header plate go against the wall. (Figure A).
3. Install extension side rails as shown in Figure A, by telescoping them inside the lower side rails. Adjust the extension side rails by sliding them up or down to ceiling height. Maximum: 8 feet 9 inches, Minimum: 7 feet 9 inches.
4. If the wall has a baseboard, cut the baseboard out to fit against the side rails. Stand the side rails against the wall and fasten them to the wall securely with screws or bolts in the holes provided. Use a level to assure the enclosure is plumb. **Screws and bolts for wall fastening are not included.**
5. After positioning the enclosure, cut a 3½ X 14 inch hole in the ceiling, centered between the studs or joists as shown in Figure B.
6. Cut ¼ inch off each end of the ceiling spacer plate. Place the ceiling spacer plate to the back of the wall and centered in the enclosure as shown in Figure C.
7. Install Type B/W vent though the roof and studs or joists in accordance with the installation instructions packed with the furnace and local codes. **See Vent Installation, page 14.**
8. Set the furnace body into position. (Figure 9), page 15. The furnace legs will rest on the bottom of the base plate panel.

Utilizing the holes provided in the furnace legs, secure the furnace to the brackets attached to the bottom panel with two (2) #10, ¼" screws.

9. Install the vent enclosure panel, fastening it to the side rails with six (6) #6, ⅝" screws. Trim the bottom of the panel to fit the header plate.
10. Install gas inlet through the back wall or one of the two holes provided in the bottom base plate panel. (Figure D.) Connect gas line to furnace. **See Gas supply and Piping, page 17.**
11. Install furnace face panel. **See Front Panel Installation, page 18.** NOTE: The panel recesses ¼-inch between the vertical edges of the enclosure.

FIGURE A

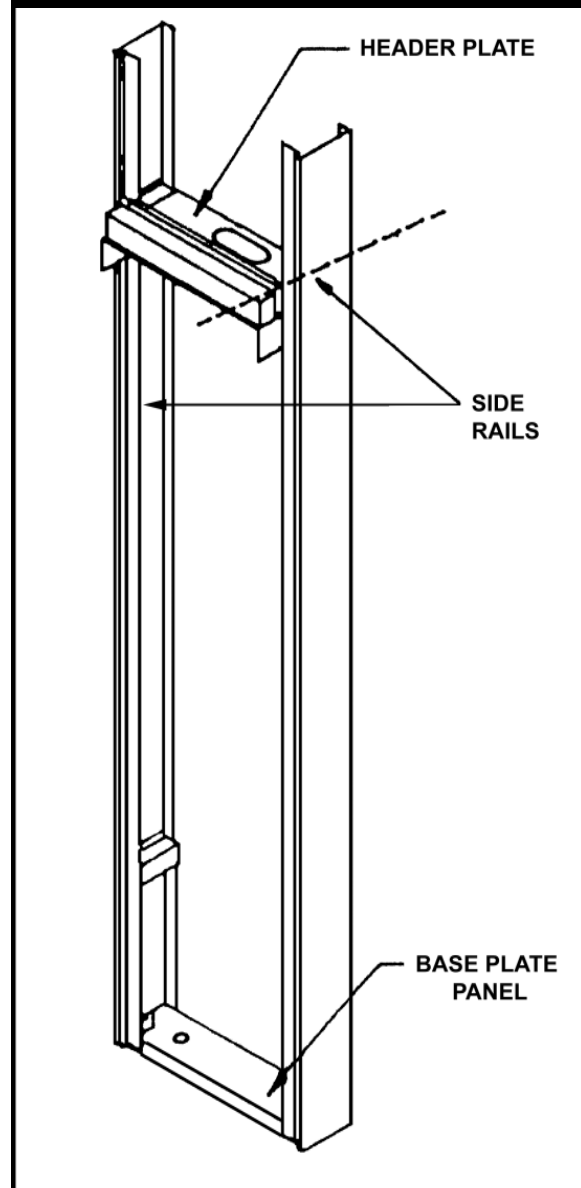

Installing Your Furnace

Surface Mount Installation (continued)

FIGURE B

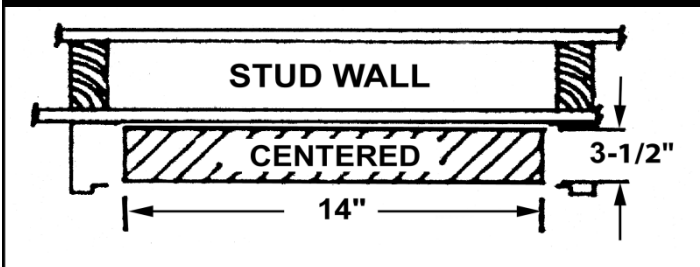

FIGURE C

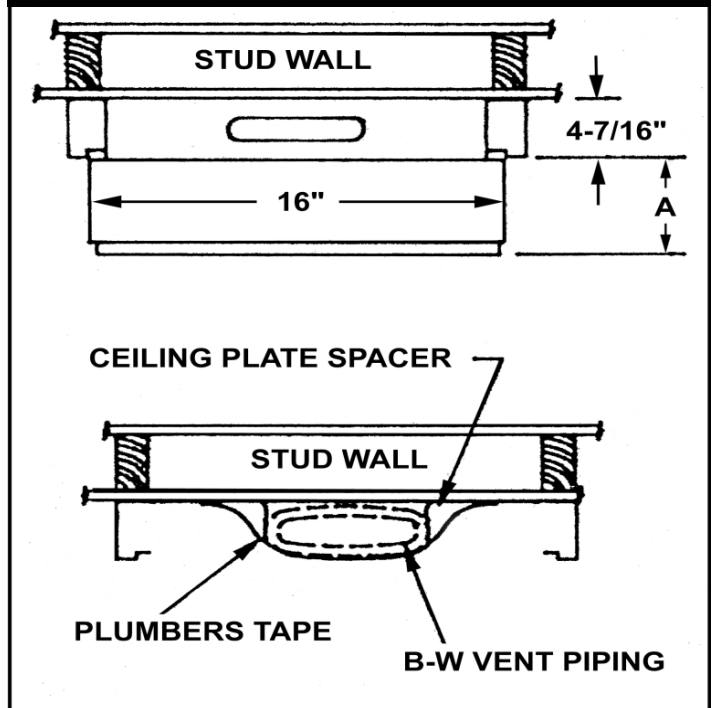
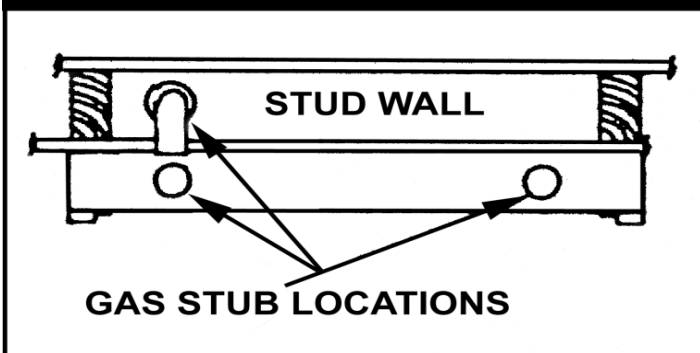
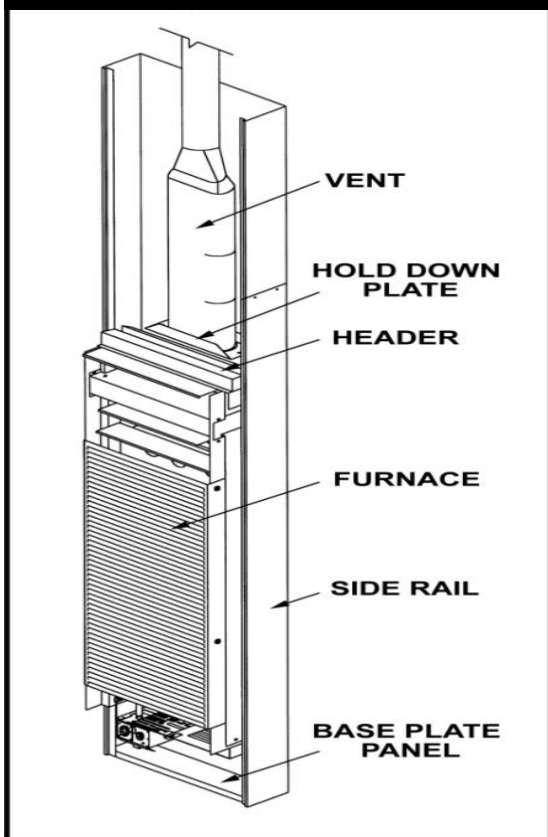

FIGURE D



Vent Installed



Front panel installed

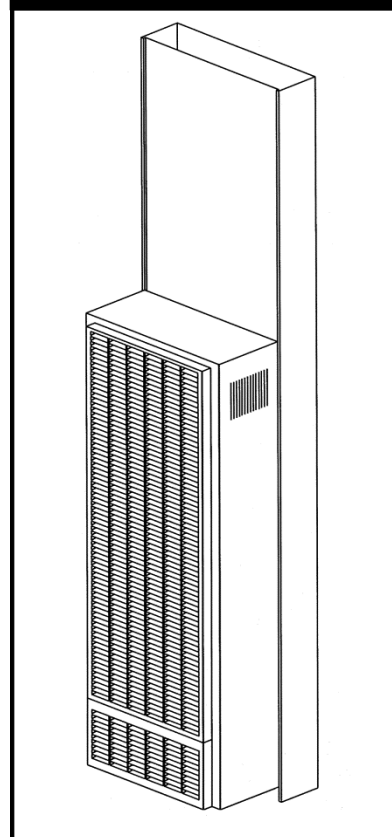

Installing Your Furnace

Vent Installation

The vent installation must comply with all local codes and ordinances. If in doubt, consult your local codes or inspector.

The furnace vent must be directed to the outdoors so that harmful combustion gases will not collect inside the building.

This furnace must not be connected to a chimney flue serving a separate solid-fuel burning appliance.

This product is design certified to ANSI Z21.86. It must be installed with a U.L. tested and listed type "B" approved vent and type "B/W" approved vent (Figure 8). Older style terra-cotta, transite, clay, concrete or masonry type vent pipe cannot be used with this appliance. These types of vent pipe will not heat fast enough to establish a draft, which will result in improper venting of combustion products. Consequently, this could cause the vent safety control system to shut down the furnace.

The area above header within the stud space **MUST** be kept clear of any attic insulation to allow the free circulation of air around the oval vent piping. In some areas the building code requires the use of an attic shield.

The B/W vent must extend through the ceiling and roof terminating at least 12-feet above the finished floor on which the furnace rests.

INSTALL FURNACE VENT

Attach a 4-foot length of oval, double-wall vent pipe through the plate spacers to the hold-down plate. Push the vent pipe into the hold-down plate until it is completely seated. The hold-down cleat will engage the groove in the vent pipe.

COMPLETE THE VENTING

Type B/W gas vent shall extend from the header plate of the furnace to a point above the highest ceiling plate within the stud space through which the vent passes, without any offsets or crossovers. The first vent pipe offset, (if required), may not be any closer than 2-feet from the header. After a type B/W gas vent passes through the highest ceiling plate within a stud space above the furnace to which it serves, the vent system may be completed with a Type B gas vent, from the **SAME** manufacturer (do not mix brands of pipe). Offsets cannot be greater than 45 degrees from vertical. Refer to The Uniform Mechanical Code.

Install the oval-to-round adapter. Complete the piping extending it through the roof. Use a 4-inch round, double-wall (Type B) vent pipe, roof flashing, storm collar and vent cap as shown. The vent cap must be at least 2-feet higher than any point that is within 10-feet of the vent cap. There must be at least a 1-inch clearance between the vent pipe and any combustible material.

Figure 8 – Typical Vent Installation

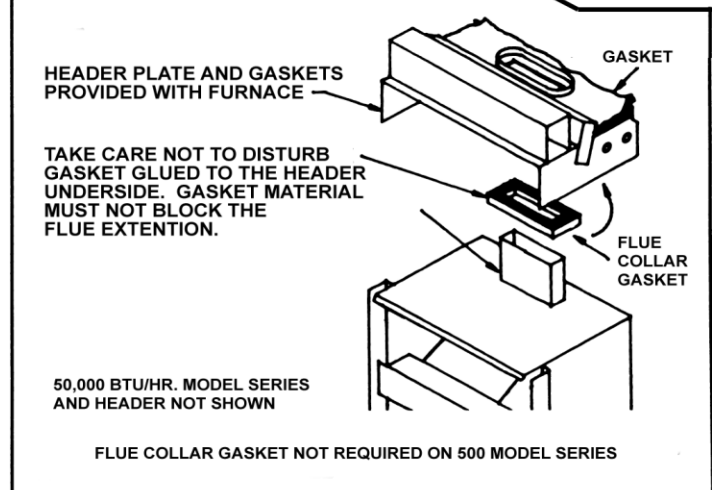
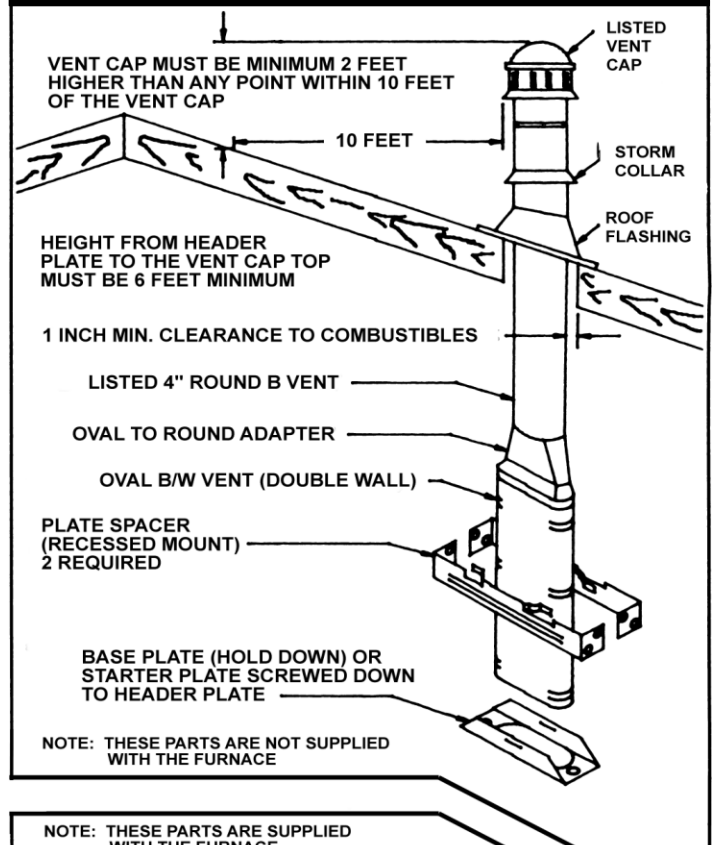

CAUTION: To avoid damage to wiring, be sure to route the wires away from the path of the furnace vent.

Installing Your Furnace

Attaching Your Furnace

Clear the wall recess of all debris, remove any wood or plaster. Stand the furnace in front of recess, holding the furnace body at an angle. Insert flue collar into the opening in the header plate and raise furnace carefully (Figure 9). Swing bottom of furnace into wall recess with front edges of legs flush with 2x4 floor plate. In the holes provided, nail through the legs into studs or floor plate (Figure 10).

FIGURE 9 – Insert Furnace

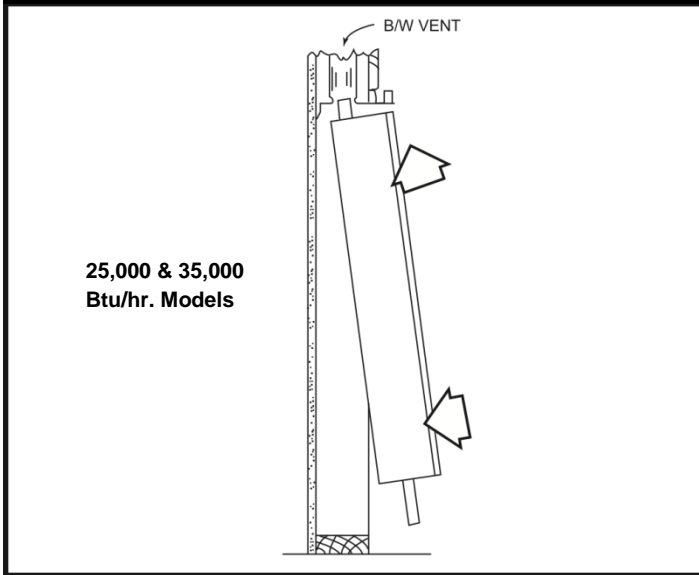
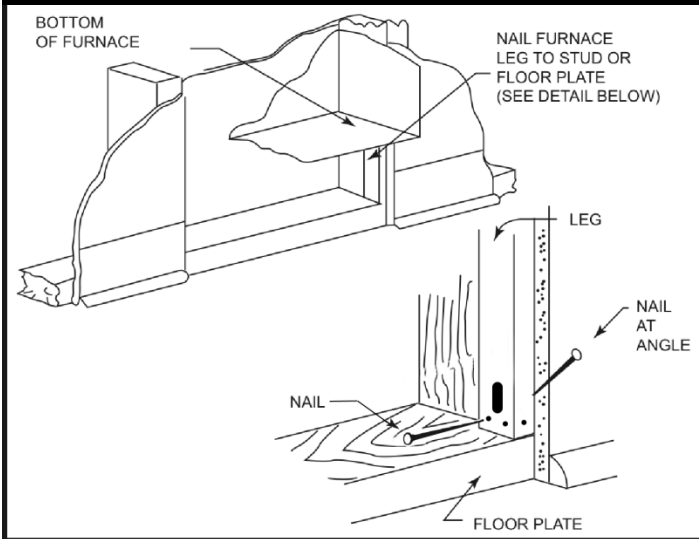

FIGURE 10 – Nail Placement



Do not damage gasket glued to underside of header plate when placing furnace in wall. Avoid nailing the legs so tightly that it disturbs the inner furnace casing. Do not try to force the furnace into a smaller-than-specified recess.

REAR OUTLET KIT INSTALLATION (OPTIONAL)

If a Rear Outlet Register Accessory is used, the following procedure must be completed before placing furnace body into wall recess. (Figure 11). Attach speed nuts to outer shield and remove knockout plates from both the outer and inner shields as follows:

1. Punch in the lower corners with a screwdriver blade.
2. Break the knockout side and bottom connecting tabs by holding a screwdriver blade sideways against the tab and striking the head of the screwdriver lightly with a hammer.
3. Swing the plate outward; bend it back and forth to break the top tabs. Use caution when handling sharp metal edges.

FIGURE 11- Remove Knockout Plates

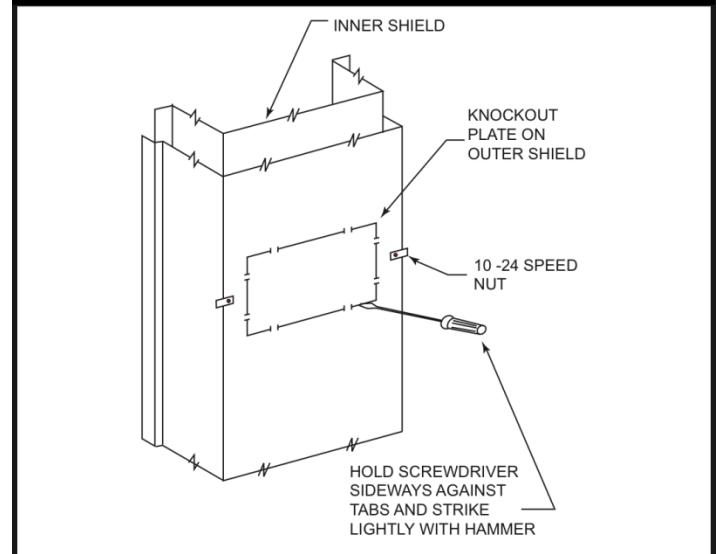

CAUTION: Do not install rear outlet kit where grille may be blocked by a door, curtains, or any other obstruction.

WARNING: Never shear or cut the furnace legs.

Installing Your Furnace

Attaching Your Furnace (continued)

After furnace is in position, install rear outlet register as shown in Figure 12. Have damper in open position when inserting the assembly. Secure the rear outlet register to speed nuts with the machine screws furnished.

FIGURE 12 – Mounting Rear Outlet Register

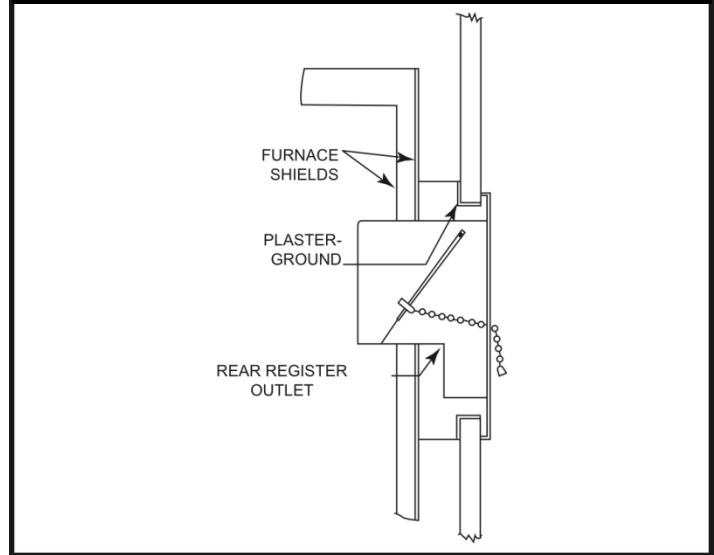

Gas Supply and Piping

The gas control valve, in the furnace, is shipped with a seal over the gas inlet tapping. Do not remove the seal until ready to connect the piping.

WARNING: Danger of property damage, bodily injury or death. Make sure the furnace is equipped to operate on the type of gas available. Models designed as natural gas are to be used with natural gas only. Models designed for use with liquefied petroleum (L.P) gas have orifices sized for commercially pure propane gas. They cannot be used with butane or a mixture of butane and propane.

GAS SUPPLY

For L.P. gas, the minimum inlet gas supply pressure for the purpose of input adjustment is 11-inches water column. The maximum inlet gas supply pressure is 13-inches water column.

For natural gas, the minimum inlet gas supply pressure for the purpose of input adjustment is 5-inches water column. The maximum inlet gas supply pressure is 7-inches water column.

Gas pressure and input to the burners must not exceed the rated input and pressure shown on the nameplate. The natural gas manifold pressure should be 4-inches water column. The manifold pressure should be 10-inches water column for L.P. gas. For operation in elevations above 2,000 feet, a burner orifice change may be required to suit the gas supplied. Check with your local gas supplier.

ORIFICE SIZES

The efficiency rating of this appliance is a product thermal efficiency rating determined under continuous operating conditions and was determined independently of any installed system. For elevations above 4,500 feet, reduce ratings 4% for each 1,000 feet above sea level.

Furnace Technical Information

| Model Number | Gas Type | Input Rating Btu/hr. | Heating Capacity Rating Btu/hr. | Main Burner Orifice | | |
|--------------|----------|----------------------|---------------------------------|---------------------|-------|------|
| | | | | Drill | Dec. | Qty. |
| 2509622 | Nat. | 25,000 | 19,350 | #43 | 0.089 | 1 |
| 2509621 | L.P. | 25,000 | 19,350 | #54 | 0.055 | 1 |
| 3509622 | Nat. | 35,000 | 25,930 | #38 | 0.101 | 1 |
| 3509621 | L.P. | 35,000 | 25,930 | #52 | 0.063 | 1 |
| 5009622 | Nat. | 50,000 | 38,000 | #44 | 0.086 | 2 |
| 5009621 | L.P. | 50,000 | 38,000 | #54 | 0.055 | 2 |

Gas Conversion Kits

Natural Gas to L.P. Gas

| Model | Description |
|-------|--|
| 8901 | 25096 Series with Williams Brand Gas Valve |
| 8902 | 35096 Series with Williams Brand Gas Valve |
| 8903 | 50096 Series with Williams Brand Gas Valve |
| 7675 | 25096 Series with Robertshaw Brand Gas Valve |
| 7676 | 35096 Series with Robertshaw Brand Gas Valve |
| 7677 | 50096 Series with Robertshaw Brand Gas Valve |

Gas Conversion kits

L.P. Gas to Natural Gas

| Model | Description |
|-------|--|
| 8904 | 25096 Series with Williams Brand Gas Valve |
| 8905 | 35096 Series with Williams Brand Gas Valve |
| 8906 | 50096 Series with Williams Brand Gas Valve |
| 9911 | 25096 Series with Robertshaw Brand Gas Valve |
| 9912 | 35096 Series with Robertshaw Brand Gas Valve |
| 9913 | 50096 Series with Robertshaw Brand Gas Valve |

Installing Your Furnace

Gas Supply and Piping (continued)

GAS PIPING

The gas supply line must be of adequate size to handle the Btu/hr. requirements and length of the run for the unit being installed.

Determine the minimum pipe size from Figure 13, based on the length of the run from the gas meter to the unit.

FIGURE 13 – Pipe Capacity

| Pipe Capacity – Btu/hr. with Fittings | | | |
|---------------------------------------|-----------|---------|---------|
| Natural Gas | | | |
| Length of Pipe-Ft | Pipe Size | | |
| | 1/2" | 3/4" | 1" |
| 20 | 92,000 | 190,000 | 350,000 |
| 40 | 63,000 | 130,000 | 245,000 |
| 60 | 50,000 | 105,000 | 195,000 |
| L.P. Gas | | | |
| Length of Pipe-Ft | Pipe Size | | |
| | 1/2" | 3/4" | 1" |
| 20 | 189,000 | 393,000 | 732,000 |
| 40 | 129,000 | 267,000 | 504,000 |
| 60 | 103,000 | 217,000 | 409,000 |

All piping must comply with local codes and ordinances or with the National Fuel Gas Code (ANSI Z223.1 NFPA No. 54), whichever applies. (In Canada: CAN/C.GA B149). Refer to FIGURE 14 for the general layout of the unit. It shows the basic fittings needed.

The following rules apply:

1. Use new, properly reamed steel or black iron pipe and fittings free of metal chips and debris that are approved by local codes. Metal chips and debris can damage the valve.
2. Do not thread pipe too far. Valve distortion or malfunction may result from excess pipe within the gas control valve. Apply a moderate amount of good quality dope to the pipe only. Leave the two end threads bare. (Figure 15). L.P. gas installations require a dope compound resistant to the action of liquefied petroleum gases. Excess dope going into the valve may cause it malfunction.
3. Use ground joint unions.
4. Install a drip leg (sediment trap) to trap dirt and moisture before it can enter the gas valve. The nipple must be a minimum of 3-inches long.
5. Install a manual shutoff valve.
6. Provide a 1/8" NPT test gauge connection immediately before the gas supply connection to the furnace.

FIGURE 14 – Gas Piping

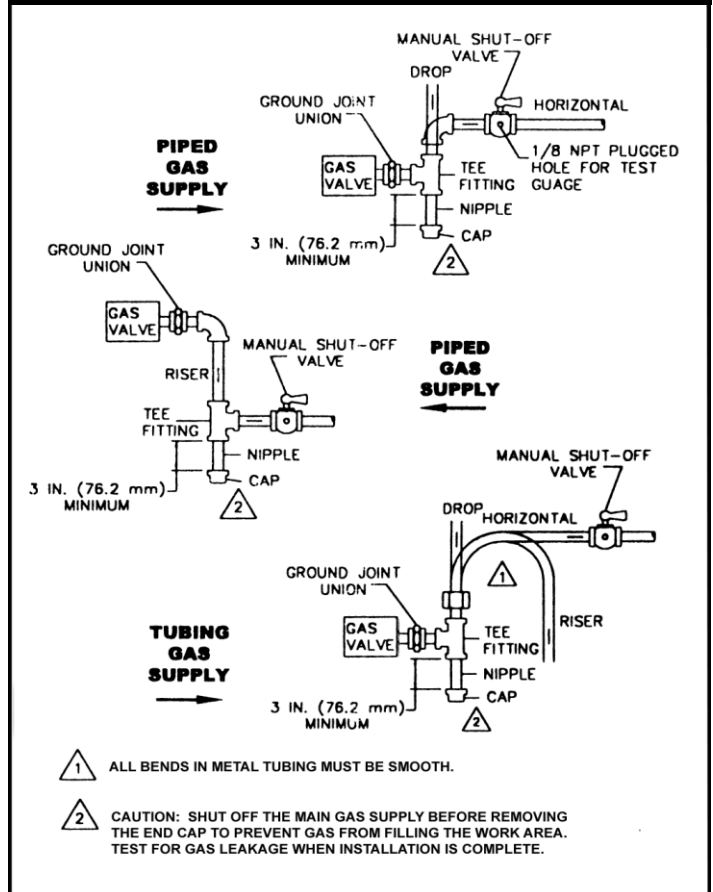

GAS CONNECTION

If the installation is for L.P. gas, have the L.P. installer use a two stage regulator and make all the connections from the storage tank.

Use two pipe wrenches when making the connection to the valve to prevent turning and/or damage to the valve.

Connections between the manual shutoff valve and burner control assembly can be made with an A.G.A./C.G.A. design certified flexible connector if allowed by local codes. Drip leg and ground joint unions are still required.

Tighten all joints securely.

FIGURE 15 – Proper Piping Practice

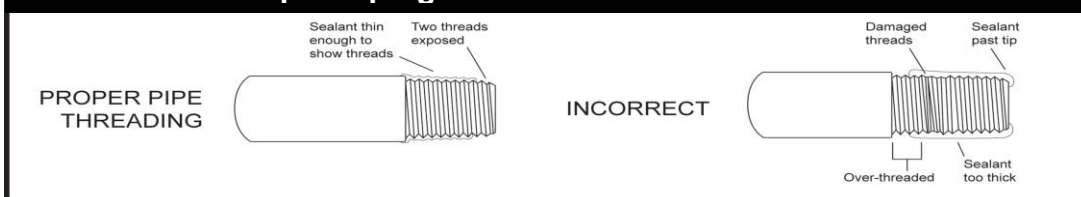

Installing Your Furnace

Gas Supply and Piping (continued)

CHECKING THE GAS PIPING

Test all piping for leaks. When checking gas piping to the furnace with gas pressure less than 1/2 PSI, shut off manual gas valve to the furnace. If gas piping is to be checked with the pressure at or above 1/2 PSI, the furnace and manual shutoff valve must be disconnected during testing. (SEE WARNING). Apply soap solution (or a liquid detergent) to each joint. Bubbles forming indicate a leak. Correct even the slightest leak at once.

WARNING: Danger of property damage, bodily injury or death. Never use a match or open flame to test for leaks. Never exceed specified pressures for testing. Higher pressures may damage the gas valve and cause over-firing which may result in component(s) failure. L.P. gas is heavier than air and may settle in any low area, including open depressions and it will remain there unless the area is ventilated.

Never attempt start-up of unit before thoroughly ventilating the area and smelling near the floor for gas odor.

Front Panel Installation

Place the front panel top over the channel on the header plate, as shown in Figure 16. Press the panel tight against wall, and secure it to the header channel with the screw provided in final assembly package. Open the control door at bottom of panel and fasten the panel at each side through slots in flanges with screws provided.

Attach handle to the front panel door with the screw provided.

Install the second face panel in same manner for 500 Series models.

FIGURE 16 – Panel Placement

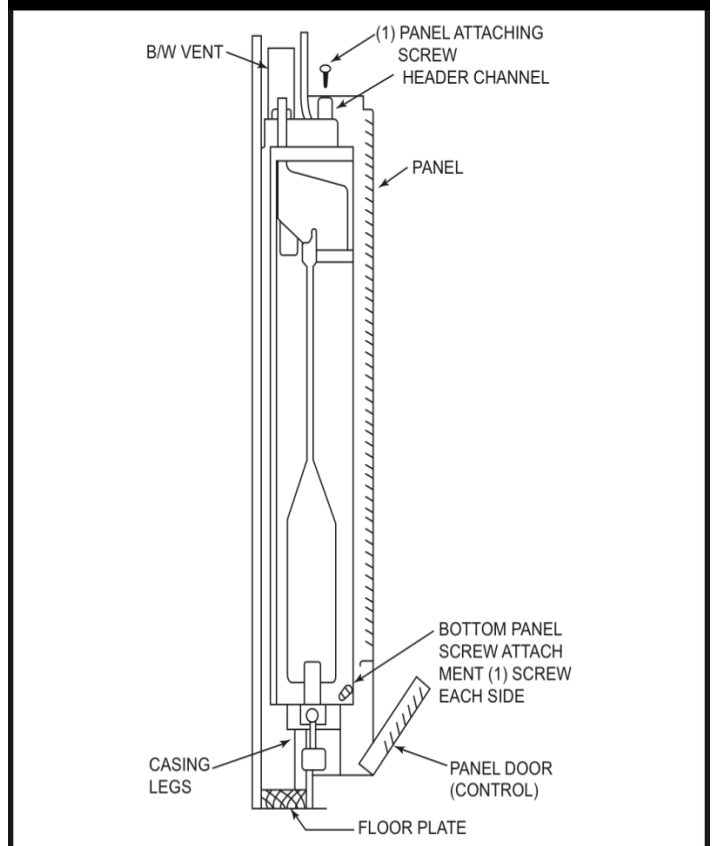

Installing Your Furnace

Thermostat Installation

Williams' furnaces are operated by a millivolt type thermostat. Current to the thermostat is supplied by the pilot generator. Do not connect it to electricity. Anticipator settings are not required.

1. Use of existing wire is acceptable if it is in a satisfactory location and the wire is in good condition. When in doubt, use new wiring.
2. If a new location is chosen or if this is a new installation, thermostat wire must first be run to the location selected. All wiring must agree with local codes and ordinances. These instructions cover bringing the wire down from the attic but it may be run from a basement or crawl space using similar methods.
3. Before drilling a hole in the wall at the selected location, drive a small finish nail through the ceiling in the corner of the wall and ceiling above the thermostat location. Pull the nail out and push a small, stiff wire through the hole so it can be found in the attic. Drill a 1/2-inch hole through the ceiling wall plate.
4. Probe for obstructions in the partition. Then, drill a 1/2-inch hole through the wall at the selected location for the thermostat.
5. From the attic, feed the thermostat wire through the wall until even with the thermostat location.
6. Snag the thermostat wire through the hole and pull the wire through the hole in the wall so that 6-inches of the wire protrude.
7. Route wires to the furnace.
8. Never use nails or staples across the thermostat wires.

CAUTION: Label all wires prior to disconnection when servicing controls. Wiring errors can cause improper and dangerous operation. Verify proper operation after servicing. Refer to installation instructions packed in the thermostat carton if you have any doubt about the above procedures.

WALL-MOUNTED THERMOSTAT INSTALLATION

1. To remove the thermostat cover, squeeze both sides and lift.
2. Connect the thermostat wires to the terminal screws on the base of thermostat.
3. Push any excess wire back through hole in the wall and plug hole with insulation to prevent drafts from affecting thermostat operation.
4. Be sure to level the thermostat for best appearance. Fasten thermostat base to the wall through mounting holes with screws provided.
5. Replace the thermostat cover.
6. Do not run wire in any location where it might be damaged. Avoid splicing the thermostat wires unless the spliced wires are properly cleaned, soldered and taped.

7. Use the 18-gauge wire as supplied for a maximum length of 20-feet. If a longer length is needed, use 16-gauge wire to a maximum length of 25-feet.
8. Connect the thermostat wires to the control valve as shown in Figure 17.

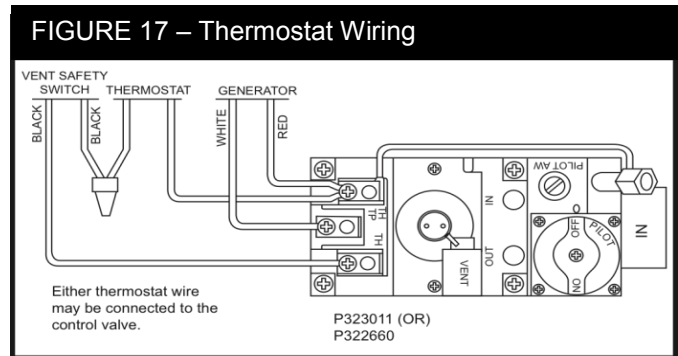

FACE PANEL-MOUNTED THERMOSTAT INSTALLATION

1. Before removing the face panel, disconnect the thermostat wires at the gas valve.
2. Locate the knockout on the right side of the furnace to mount the thermostat. Remove the knockout by tapping it lightly with a screwdriver (Figure 18). It will also be necessary to cut a 1/2-inch hole in the inside panel insulation for clearance to the knockout.
3. Cut the thermostat wire to 56 inches.
4. Connect the thermostat wires to terminal screws on the thermostat base.
5. Feed the thermostat wires through the knockout and route them through the metal clip to the gas valve.
6. Mount the thermostat to the side of the cabinet with screws provided.
7. Replace the thermostat cover.
8. Connect the thermostat wires to the control valve as shown in Figure 17.

FIGURE 18 Knockout Holes

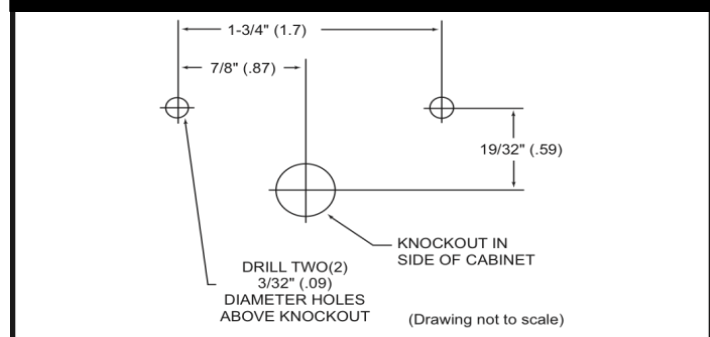

IMPORTANT: Keep the thermostat wires away from the combustion chamber.

Installing Your Furnace

Start-Up Procedure

WARNING: Danger of property damage, bodily injury or loss of life. Liquefied Petroleum (L.P.) Gas is heavier than air and may settle in any low area, including open depressions and may remain there unless area is ventilated. Never attempt start-up of unit before thoroughly ventilating the area.

Check the furnace operation as outlined in the following instructions. If any sparking, odors or unusual noises are encountered, shut off electric power immediately. Recheck for wiring errors or obstructions in or near fan motor (if equipped).

WARNING: Natural gas heating value (Btu per cubic foot) can vary significantly. Therefore, it is the installer's responsibility to see that Btu/hr. input to the furnace is adjusted properly. Failure to do so could cause combustion chamber failure, asphyxiation, fire or explosion resulting in damage, bodily injury or death. Refer to the National Fuel Gas Code (NFPA 54) to be sure the furnace is burning fuel at the proper rate.

CHECK GAS INPUT AND PRESSURES

For furnaces located at elevations between sea level and 4,500 feet, the measured input must not be greater than the input shown on the nameplate of the furnace. For elevations above 4,500 feet, the measured input must not exceed the input on the nameplate reduced by 4 percent for each 1,000 feet that the furnace is above sea level.

Gas supply pressure and manifold pressure with the burner(s) operating must also be as specified on the nameplate.

Rated input will be obtained on a heating value of 2,500 Btu/hr. for propane at 10-inches manifold pressure with factory-sized orifices. If L.P. gas having a different heating value is supplied, orifices must be changed by a qualified service technician before the furnace is operated.

| Type of Gas | Manifold Pressure, In. W.C. |
|-------------|-----------------------------|
| Natural | 4.0 |
| L.P. | 10.0 |

CHECK THE MANIFOLD GAS PRESSURE

A tapped opening is provided in the gas valve to facilitate measuring manifold gas pressure. A water column manometer having a scale range from 0 to 12-inches of water column should be used for this measurement. The manifold pressure must be measured with the burner and pilot operating. Any major changes in the flow must be made by changing the size of the burner orifice.

CHECK THE GAS INPUT (NATURAL GAS ONLY)

Under firing could cause inadequate heat, excessive condensation or ignition problems. Over firing could cause shooting flame impingement or overheating of the combustion chamber. Before starting natural gas input check, obtain the heating value of gas (Btu per cubic foot) at standard conditions from your local gas supplier.

To measure the input, using the gas meter, proceed as follows:

1. Turn off gas supply to all other appliances except the furnace.
2. With the furnace operating, time the smallest dial on the meter for one complete revolution. If this is a 2-cubic-foot dial, divide the seconds by 2. If it is a 1-cubic-foot dial, use the time in seconds as is. This gives the seconds per cubic foot of gas being delivered to the furnace.
3. Assuming natural gas with a heating value of 1,000 Btu per cubic foot and 34-seconds per cubic foot used as determined by step (2), then:

$$\text{Seconds per hour} = 3,600$$

$$\text{Input} = 1,000 \times 3,600 / 34 = 106,000 \text{ Btu/hr.}$$

This measured input must not be greater than the input indicated on the nameplate of the furnace.

4. Relight all other appliances turned off in Step 1 above. Be sure all pilots are operating.

CHECK THERMOSTAT

Check thermostat operation. When set above room temperature shown on the thermostat, the main burner should light. Make certain the thermostat turns off the furnace when the room temperature reaches the selected setting and starts the furnace when room temperature falls a few degrees below the thermostat setting.

CHECK GAS CONTROL VALVE WIRE CONNECTIONS

Gas Control Valve Wiring - P323011 or P322660

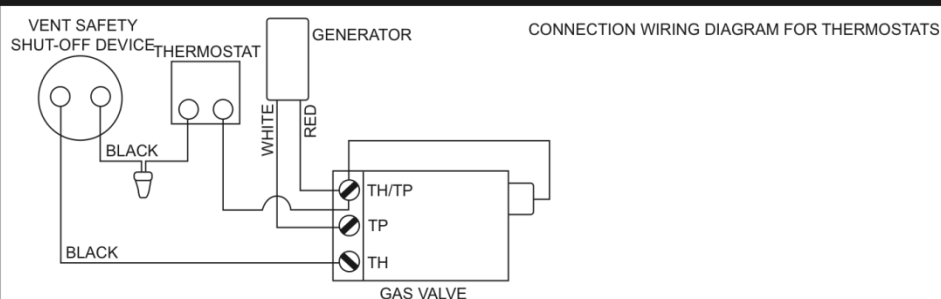

LEGEND

— FACTORY WIRED LOW VOLTAGE

⊗ SCREW TERMINAL LOW VOLTAGE

NOTES: IF ANY OF THE ORIGINAL WIRE AS SUPPLIED WITH THE APPLIANCE MUST BE REPLACED. USE ONLY 18GA. 4/64 INSULATION. 105 C, AWM COPPER WIRE OR EQUIVALENT. FOR FIELD WIRED CONNECTIONS USE NO. 18 AWG WIRES RATED FOR AT LEAST 105 C (221 F).

Operating Your Furnace

Start-Up Procedure (continued)

CHECK PILOT BURNER

The pilot flame must surround the generator tip from 1/4 to 3/8-inches. Pilot flame is preset at the factory, so ordinarily it does not require field adjustment. (Figure 19). On new installations, the gas lines will be filled with air and may take several minutes to establish a pilot flame.

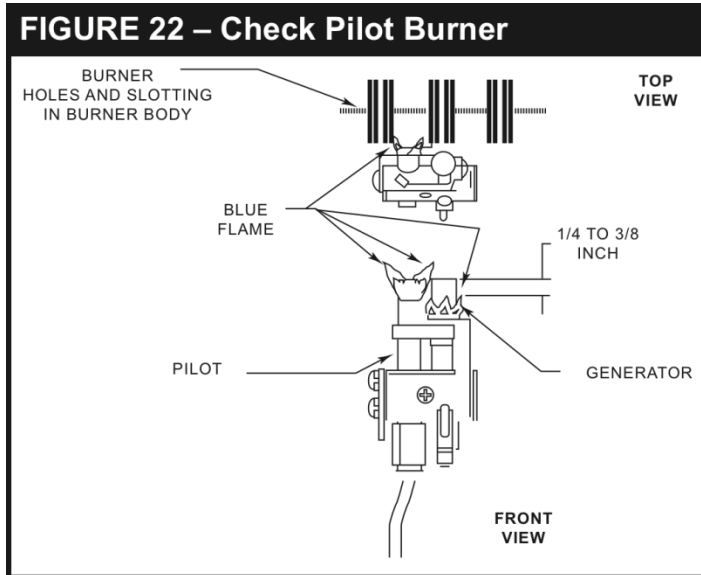
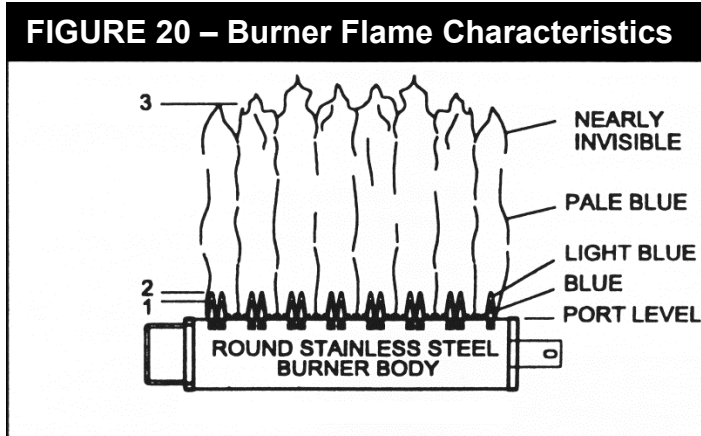

FIGURE 19 – Check Pilot Burner

BURNER FLAME CHARACTERISTICS

Start the furnace and let it operate at least ten minutes. Open the access door to view the burner flame. Limit your movements near the furnace a few more minutes before making your final observations. The flame may look yellow due to dust particles in the room air. The flame should change to a nice blue color with firm inner and secondary cones. An occasional flash of orange might be seen as dust particles burn in the flame. This is normal. No burner adjustment is provided, or is necessary. (Figure 20).



NORMAL APPEARANCE

Natural Gas:

1. Inner cone—blue in color—3/8 to 5/8-inches above ports.
2. Secondary inner cone—light blue in color—1 to 2-inches above ports.
3. Total flame—from blue in color to nearly invisible—approximately 6-inches above ports.

L.P Gas:

1. Inner cone—blue in color—1/2 to 3/4-inches above ports.
2. Secondary inner cone—light blue in color—1 to 2-inches above ports.
3. Total flame—from blue in color to nearly invisible—approximately 6-inches above ports.

ABNORMAL APPEARANCE

Lazy Flame:

Long, soft yellow cones moving around in the combustion chamber lifting from ports (insufficient air).

Extremely Fast Flame:

Flame will not hold to ports—entire cone sections blow off from noisy ports (too much pressure).

WARNING: If flame appears abnormal, contact the gas company or a qualified service technician immediately.

Operating Your Furnace

FOR YOUR SAFETY, READ BEFORE LIGHTING THE PILOT

WARNING: If you do not follow these instructions exactly, a fire or explosion may result causing property damage, personal injury or loss of life.

LIGHTING THE PILOT

- A. This appliance has a pilot which may be lit by hand. When lighting the pilot, follow these instructions exactly.
- B. BEFORE LIGHTING smell around the appliance area for gas. Be sure to smell next to the floor because some gases are heavier than air and will settle on the floor.
- C. Use only your hand to push in or turn the gas control knob. Never use tools. If the knob will not push in or turn by hand, don't try to repair it, call a qualified service technician. Force or attempts to repair may result in a fire or explosion.

- D. Do not use this appliance if any part has been under water. Immediately call a qualified service technician to inspect the appliance and to replace any part of the control system and any gas control which has been under water.

E. WHAT TO DO IF YOU SMELL GAS

- Do not try to light any appliance or strike a match.
- Do not touch any electrical switch; do not use any phone or cell phone in your building.
- Immediately call your gas supplier from a neighbor's phone. Follow the gas supplier's instructions.
- If you cannot reach your gas supplier, call the fire department.

IMPORTANT:
KEEP BURNER AND CONTROL COMPARTMENT CLEAN.

OPERATING INSTRUCTIONS

1. **STOP!** Read the safety information above.
2. Set the thermostat to lowest setting.
3. If applicable, turn off all electric power to the appliance.
4. Open control access panel.
5. Push in gas control knob slightly and turn clockwise  to "OFF". (Figure 21).

9. Turn knob on the gas control counterclockwise  to "PILOT".

FIGURE 21 – Gas Control Knob

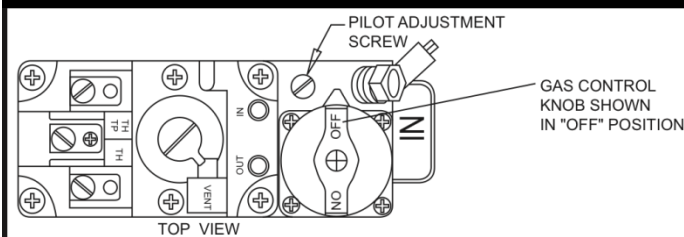
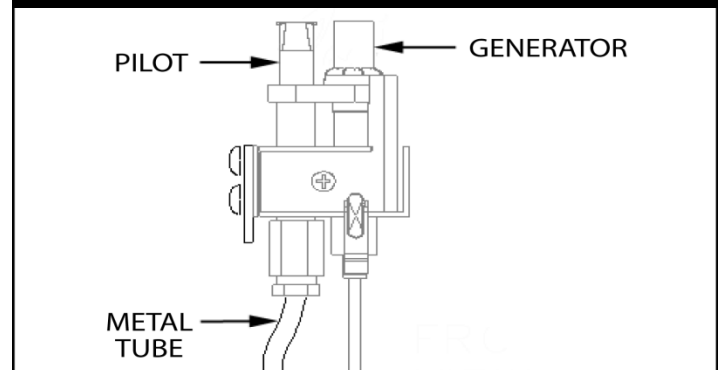



FIGURE 22 – Pilot and Generator



6. Wait five (5) minutes to clear out any gas, then smell for gas, including near the floor. If you then smell gas, **STOP!** Follow "E" in the safety information above. If you don't smell gas, go to the next step.
7. Loosen wing nut and open the pilot observation door (if equipped).
8. To find the pilot, follow metal tube from the gas control. The pilot is mounted on the side of the burner. (Figure 22).

10. Push in the control knob all the way and hold in. Immediately light the pilot. Continue to hold the control knob in for about one (1) minute after the pilot is lit. Release the knob and the pilot flame will pop back up. The pilot should remain lit. If it goes out, repeat Steps 5 through 10.

- If knob does not pop up when released, stop and immediately call your service technician or gas supplier.
- If the pilot will not stay lit after several tries, turn the gas control knob "OFF" and call your service technician or gas supplier.

11. Close pilot observation door, tighten wing nut (if equipped).
12. Turn gas control knob counterclockwise  to "ON".
13. Close control access panel.
14. Turn on all electric power to the appliance (if applicable).
15. Set thermostat to desired setting.

Operating Your Furnace

FOR YOUR SAFETY, READ BEFORE LIGHTING THE PILOT (continued)

TO TURN OFF GAS TO APPLIANCE

1. Set the thermostat to lowest setting.
2. Turn off all electric power to the appliance if service is to be performed (if applicable).
3. Remove control access panel.
4. Push in gas control knob slightly and turn clockwise  to "OFF". Do not Force.
5. Replace control access panel.

IMPORTANT:

KEEP BURNER AND CONTROL COMPARTMENT CLEAN.

WARNING: Due to high surface temperatures, keep children, clothing, furniture or any combustible material away from the furnace.

OPERATION OF YOUR FURNACE

THE FURNACE OPERATES IN THE FOLLOWING SEQUENCE:

1. Thermostat turns on the main burner.
2. Heat builds up in the furnace and starts the fan (if equipped). The heated air comes out the front panel louvers.
3. When the thermostat setting is reached, it shuts off the main burner.
4. The fan runs until the heat is removed from the furnace, then it turns off (if equipped).

Your furnace is equipped with a 100% safety pilot that will shut off the gas supply in case the pilot is not burning or functioning properly. Make sure the pilot is adjusted properly and that the pilot generator connection at the control valve is tight. If the furnace will not stay lit, call your local gas utility or a qualified service person.

If furnace is equipped with a manual spark igniter, follow these steps:

1. Review the pilot lighting instructions.
2. When instructed to "Light the Pilot," depress the red button located on the burner pan for pilot ignition. If necessary, depress the red button vigorously several times for pilot ignition.
3. If pilot fails to ignite or a spark is not present while actuating the red button or by using a match, repeat steps 5 through 10 listed in "Lighting the Pilot."

WARNING: The surface of the furnace is hot during operation. Keep children, clothing, furniture, and flammable material away from it. Keep all access doors and panels in place except for inspection and maintenance. On new installations, the gas lines will be filled with air and it may take several minutes to establish the pilot flame.

WARNING: Danger of property damage, bodily injury or death. If the furnace overheats or fails to shut off, close manual shutoff gas valve to the furnace before turning off electrical power to the accessory fan.

WARNING: Protect your eyes against the danger of ignition flash and eye injury or blindness. Never attempt to light the pilot with the gas control valve knob in the "ON" position. Flashback could occur.

Caring for Your Furnace

How to Care for Your Furnace

WARNING: Danger of bodily injury or death. Turn off electric power supply at disconnect switch, fuse box or service panel before removing any doors or access service panels from unit.

ANNUAL UPKEEP NEEDED

It is recommended that a qualified service technician perform these maintenance checks at the beginning of each heating season.

CABINET FINISH

Clean cabinet with damp cloth. Never use abrasive cleaners. Cabinets are finished with heat resistant powder paint. Never refinish or paint.

FURNACE AREA

Keep the area near the furnace clear and free from combustible materials, gasoline and other flammable liquids and vapors.

COMBUSTION AND VENTILATION AIR

The combustion and ventilation air supply must not be blocked. Do not put anything in or on the furnace cabinet. For better circulation and more effective heating, do not place obstructions, furniture or other items closer than four-feet in front of the furnace or two-feet from each side of the furnace.

CLEANING BLOWER (IF APPLICABLE)

Shut off electricity. Clean any lint or dirt from fan blades, fan motor and exposed air passages.

BURNER CLEANING

If cleaning is required, contact a qualified service technician to clean and service burner. To remove burner(s):

1. Open burner compartment door.
2. Shut off gas supply to furnace.
3. Disconnect gas line inside cabinet at ground joint union fitting. (Figure 24).
4. Remove (2) screws securing burner pan assembly to inner liner.
5. Pull burner pan assembly forward approximately 1/2-inch and drop down to expose the top of the burner.
6. Clean all foreign materials from the top of the burner.
7. After cleaning, replace burner pan assembly by reversing above procedure.

PILOT BURNER

Using the instructions in "Lighting the Pilot", leave thermostat at its lowest setting. Pilot flame should surround the generator tip 1/4 to 3/8-inches. If flame needs adjusting, do so as follows:

1. Insert small screwdriver into the pilot adjusting screw (Figure 23). Adjust flame as needed. Turn screw counterclockwise to increase flame, clockwise to decrease.
2. Turn thermostat to highest setting. Main burner should light quickly and smoothly. Turn thermostat to lowest setting. Main burner should go out. Pilot should remain lit.

FIGURE 23 – Adjusting the Pilot

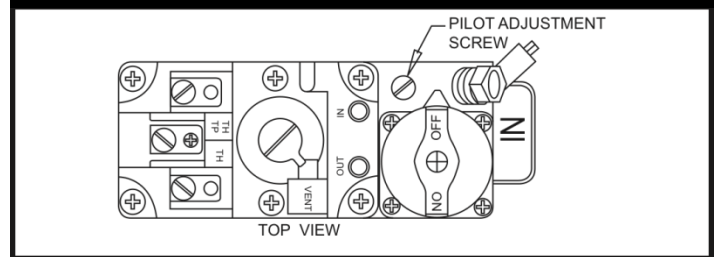

VENT SYSTEM

Make sure that no parts of the venting system are blocked or rusted. Clean or replace before using the furnace.

FIGURE 24 – Disconnecting Gas Line

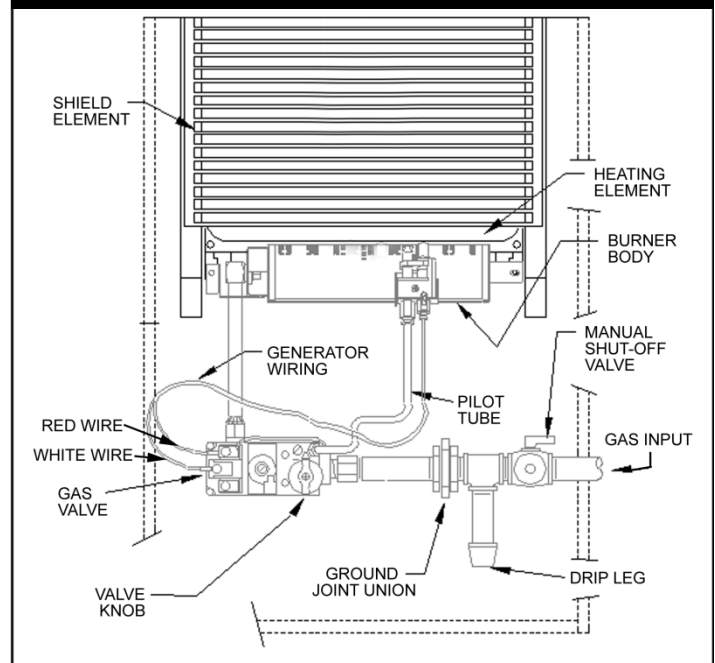

Caring for Your Furnace

How to Care for Your Furnace (continued)

CLEANING THE BURNER COMPARTMENT

Because cold air is attracted to the flame during furnace operation, a buildup of lint from carpeting, bedding, dust, etc. in the burner area will occur. It is necessary to clean this area regularly. Use a vacuum cleaner with a narrow attachment to reach small areas. Be careful in and around the pilot. A change in its adjustment could be made if moved during cleaning. A properly adjusted burner with nearly all gases will produce a flame which has clear blue cone having a bluish-red or bluish-violet outer mantle.

DANGER: The build-up of any dust, lint or foreign material in the primary air opening of the burner can interfere with the proper air gas mixture and can result in a yellow flame which can produce carbon monoxide and soot. This condition, if allowed to develop, can lead to bodily injury including death. It is imperative that the burner be kept clean.

Installing Your Blower Accessory

Blower Accessory 2901 and 2907

This blower accessory is installed on the furnace top and increases circulation of warm air through the heated space. A 115V electrical outlet adjacent to the furnace is required. For automatic setting, you must select the "HI" or "LOW" fan switch position. When the furnace heats up, the automatic fan switch will be activated and the fan will operate. The blower accessory will not operate if the fan switch is set in the "OFF" (center) position. Be sure this accessory is of the type and design required for use with your furnace.

1. Turn off electric power supply at the disconnect switch, fuse box or service panel before installation or service to the blower accessory.
2. Label all wires prior to disconnection when servicing. Wiring errors can cause improper and dangerous operation. Verify proper operation after servicing.
3. Install a 115V electrical outlet as shown in Figure A.
4. Remove the two (2) screws securing the blower grille and remove the blower grille as shown in Figure B.
5. Remove the two (2) screws securing the junction box cover. Remove the cover to gain access to the knockout located in the junction box.
6. Locate the knockout and remove it using a hammer and screwdriver. Use caution when handling sharp metal edges.
7. Place the blower body on furnace top as shown in Figure B.
8. Route 115V wiring into the junction box through the knockout.
9. Make wiring connections inside the junction box as shown in Figures C and D. Follow applicable local and national electrical codes. All electrical work must conform to your local codes and ordinances or in their absence, with National Electrical Code, NFPA 70/ANSI. If you are not

familiar with wiring codes in general, have a competent electrician do this job.

Drill a 1/8-inch diameter hole in each side of the furnace face panel through the holes located on the sides of the fan cabinet. Secure the blower to the furnace with the two screws provided.

10. Replace the junction box cover, securing it with the screws previously removed
11. Replace the blower grille, securing it with the screws previously removed.
12. Set the switch to the desired position. If left in "HI" or "LOW" position during the summer months, the blower could be activated by heat. If this is undesirable, set the switch to the "OFF" position.

CAUTION: Danger of property damage, bodily injury or death. Turn off electric power supply at the disconnect switch, fuse box or service panel before removing or working on the fan cabinet.

Installing Your Blower Accessory

Blower Accessory 2901 and 2907 (continued)

FIGURE A – Install Electrical Outlet

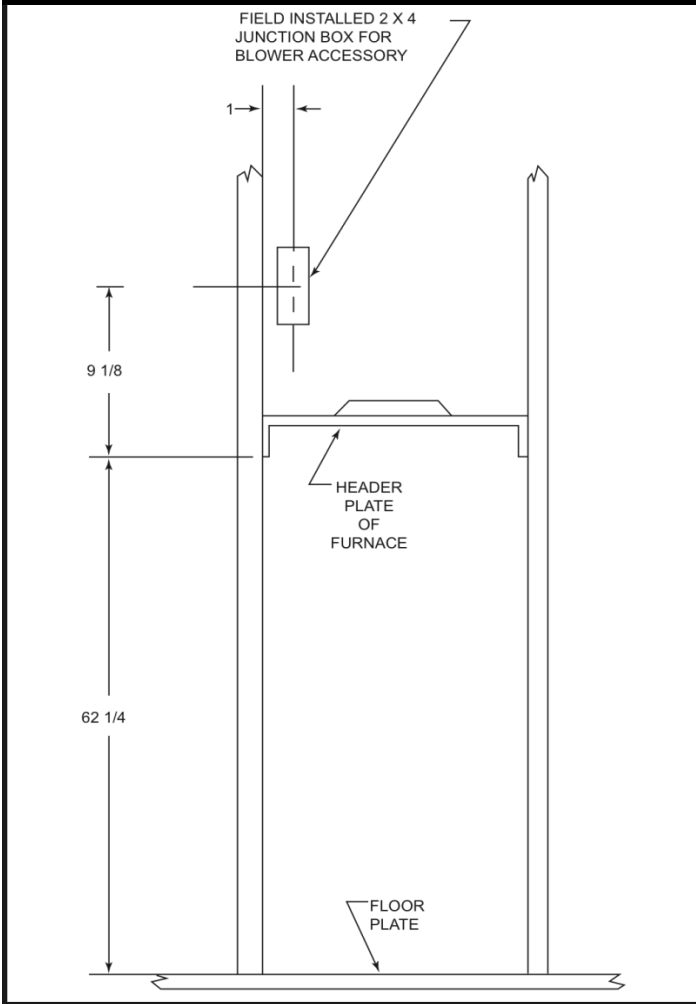

FIGURE B – Install Blower Body

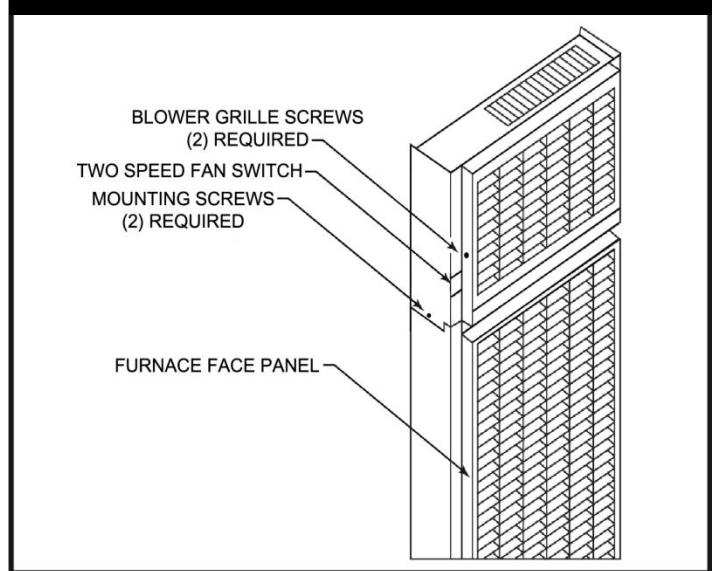

FIGURE C – Wiring for Model 2901

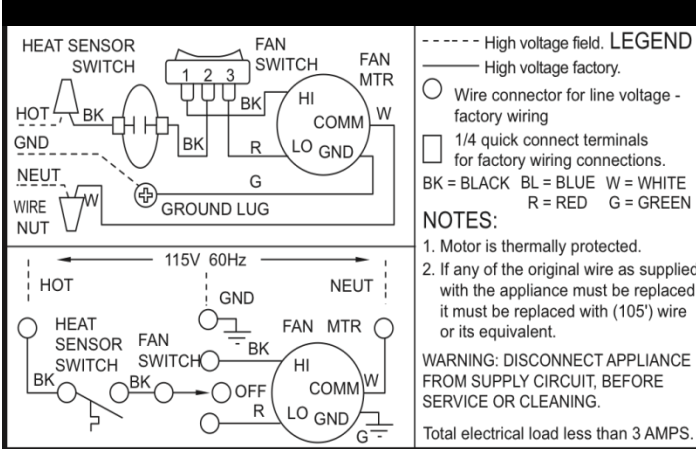
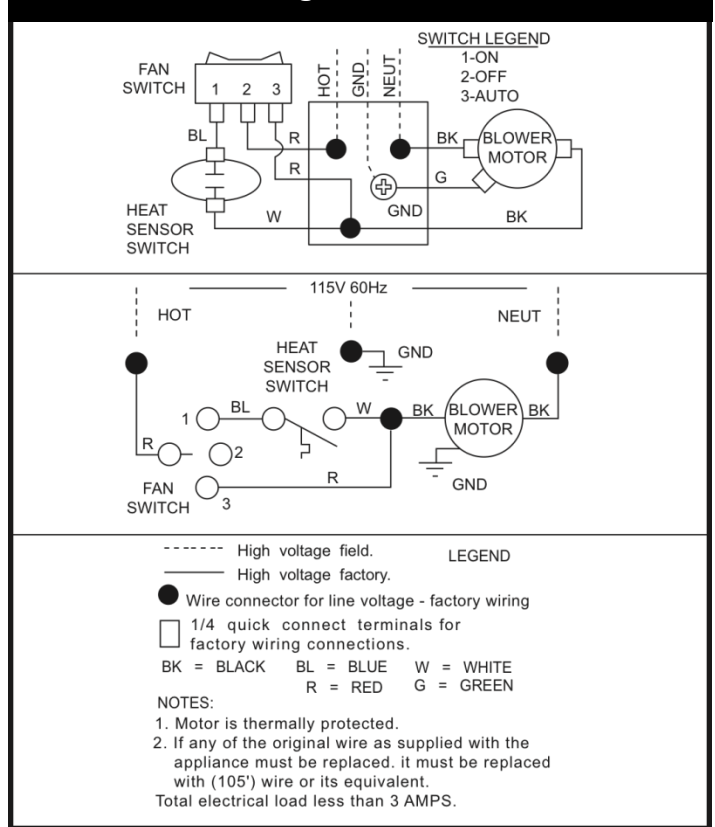
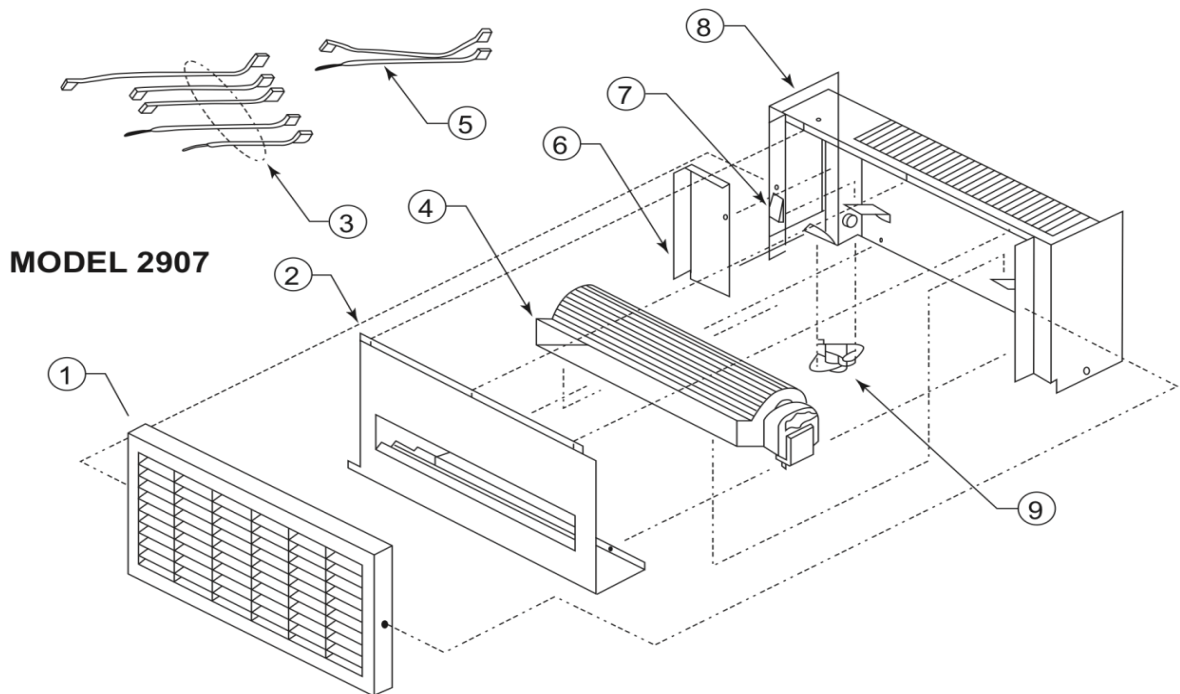
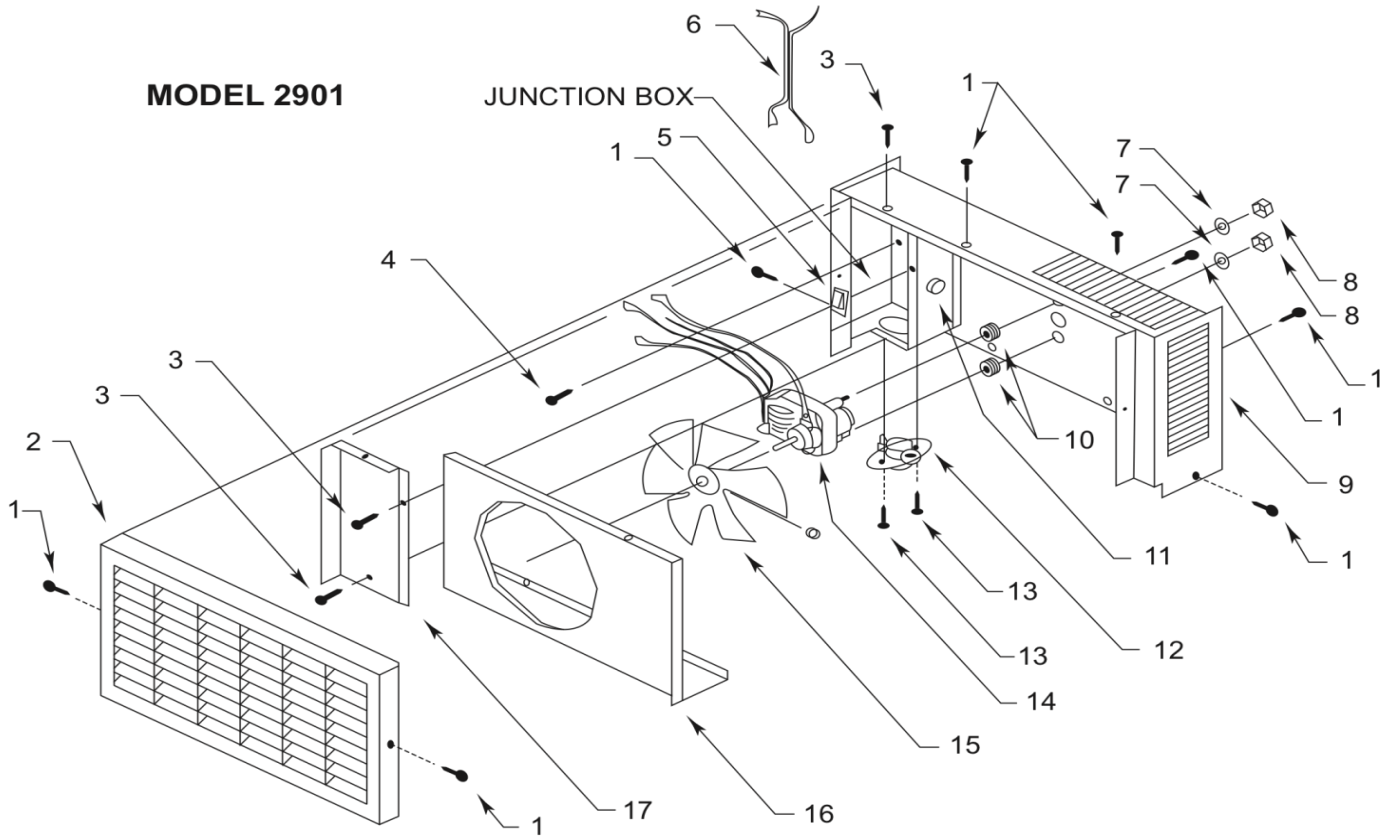

FIGURE D – Wiring for Model 2907



Blower Accessory Replacement Parts

BLOWER ACCESSORY 2901 and 2907



Blower Accessory Replacement Parts

Blower Accessory 2901 and 2907 (continued)

BLOWER ACCESSORY PARTS - MODEL 2901

| Ref. No. | Description | Part No. |
|----------|----------------------------------|----------|
| 1 | Screw - #8Ax 3/8 (8) | P013200 |
| 2 | Blower Grille | 9C99 |
| 3 | Screw - #8Ax 3/8 (8) | P093200 |
| 4 | Screw - #10 x 1/2 | P141000 |
| 5 | Toggle Switch | P320911A |
| 6 | Wire Bridle | P320912 |
| 7 | Flat Washer - #10-31 (2) | P127300 |
| 8 | Machine Nut - #8-32 w/Washer (2) | P041100 |
| 9 | Blower Body | 9C102 |
| 10 | Motor Mount Grommet (2) | P321078 |
| 11 | Strain Relief Bushing | P012900 |
| 12 | Fan Switch | P323095 |
| 13 | Screw - #6-32 x 3/8" | P029200 |
| 14 | Motor | P320905 |
| 15 | Fan Blade | P320907 |
| 16 | Orifice Plate | 9D12-1 |
| 17 | Junction Box Cover | 9B161 |

BLOWER ACCESSORY PARTS - MODEL 2907

| Ref. No. | Description | Part No. |
|----------|---------------------------|----------|
| 1 | Blower Grille | 9C99 |
| 2 | Orifice Plate | 9B246 |
| 3 | Wire Assemblies | 9B248 |
| 4 | Blower and Motor | P323076 |
| 5 | Heat Sensor Wire Assembly | P320912 |
| 6 | Junction Box Cover | 9A483 |
| 7 | Fan Switch | P323080 |
| 8 | Blower Body | 9B249 |
| 9 | Heat Sensor Switch | P323095 |

Use only manufacturer's authorized parts.

NOTE: Nuts, bolts, screws, and washers are standard hardware items and may be purchased locally.

Installing Your Motorized Rear Outlet Accessory

Motorized Rear Outlet Register 6919 and 6920

WARNING: Danger of property damage, bodily injury or death. Turn off all electrical power supply at disconnect switch, fuse box or service panel before removing or working on fan. For your protection against shock hazard, this appliance is equipped with a three-prong (grounding) plug and should be plugged directly into a properly grounded three-prong receptacle. Do not cut or remove the prong. All electrical work must conform to your local codes and ordinances or in their absence, with National Electrical Code ANSI/NFPA 70. In Canada, use the Canadian Electrical Code C22.1. If you are not familiar with the wiring codes in general, have a competent electrician do this job.

4. Attach speed nuts to the outer shield (Figure B). After the furnace is in position, insert the outlet register into the opening as shown in Figures C, D and E. Install machine screws through the register housing and into the speed nut clips on the furnace outer shield. Do not over tighten the screws.
5. After the register has been either wired, (Figure F), or plugged in, set the fan switch to the desired blower operation.

CAUTION: Do not install this kit where the outlet grille may be blocked or covered by a door, curtains or any other obstructions.

MOTORIZED REAR OUTLET REGISTER 6919 AND 6920

This Rear Outlet Register directs some of the heated air into the room opposite the one in which the furnace is installed. Read these instructions carefully and familiarize yourself with the installation before you begin. Use gloves to protect your hands from sharp metal edges.

BLOWER SETTINGS

You must select "ON" for continuous blower operation or "AUTO" for automatic setting. If the blower is set on "AUTO" when the furnace heats up, the heat sensor switch is activated and the blower will operate until the furnace cools down, then the blower will turn off. The blower will not operate if fan switch is set in the "OFF" (center) position.

LOCATION WARNING

This register must be centered between studs and aligned with the furnace for proper engagement. Make sure the furnace is centered between the same studs before you cut any wall openings for the register.

1. Measure and mark wall for opening as shown in Figure A. Check the wall for any electrical wiring present before cutting the opening. Reroute existing electrical if necessary.
2. If recessed-mounted installation, place the plaster ground in the opening and attach to the 2x4 studs.
3. An embossed knockout plate is located on the rear of the outer shield and another is located directly behind it on the inner shield. (Figure B). Remove the knockout plates on the furnace by punching in the lower corners of the plate with a screwdriver blade. Then, holding the screwdriver blade sideways against the side and bottom connecting tabs, strike the head of the screwdriver lightly with a hammer to break the tabs. Swing the plate outward and bend it back and forth to break the top tabs. Both knockout plates must be removed in order to attach the register assembly properly. If the inner shield knockout is not embossed deep enough to be removed easily, mark an outline using the existing opening as a guide. Use tin snips to cut the area away. A pilot hole may be needed to begin the first cut. Take care not to damage the combustion chamber directly behind the inner shield when making a pilot hole.

FIGURE A- Recessed & Surface Installation

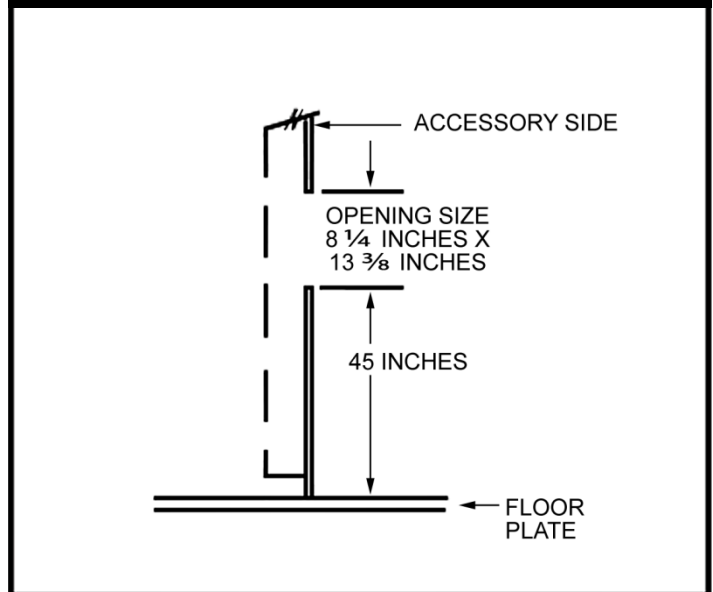
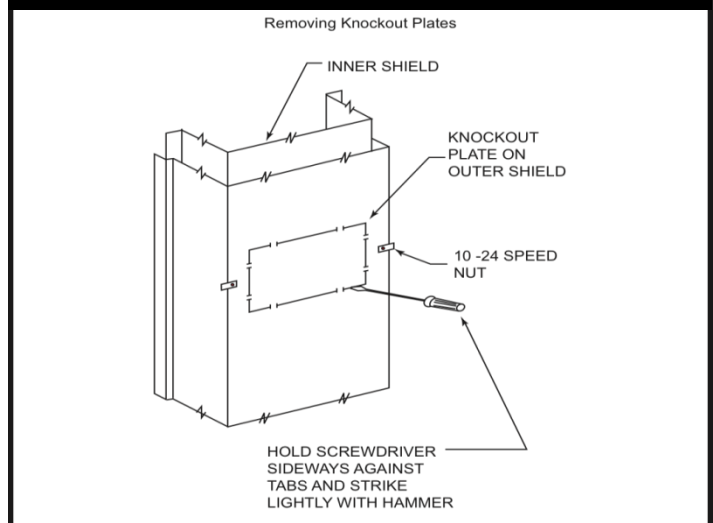

FIGURE B – Removing Knockout plates



Installing Your Motorized Rear Outlet Accessory

Motorized Rear Outlet Register 6919 and 6920 (continued)

FIGURE C – Surfaced Mounted Installation

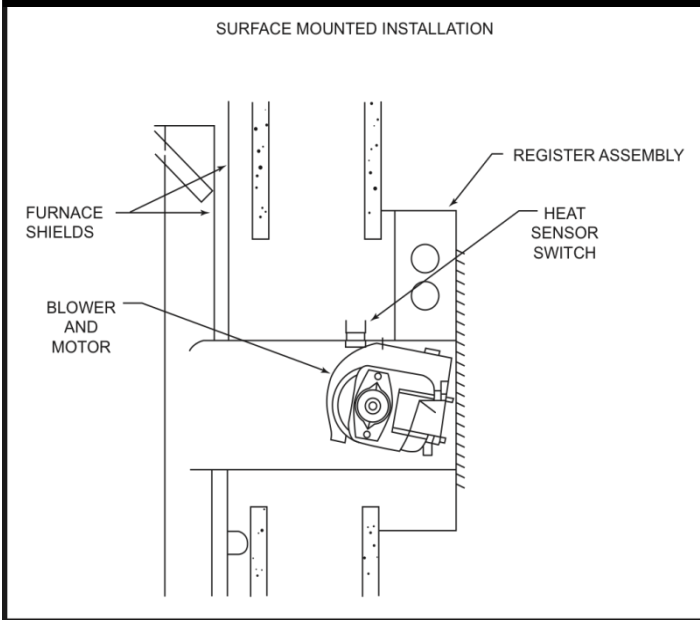

FIGURE D – Recessed Mounted Installation

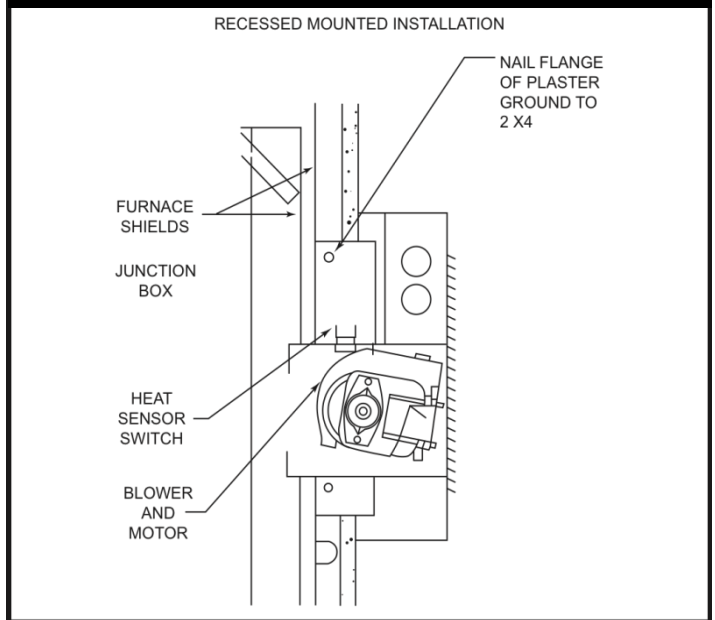

FIGURE E – Surface Mounted Installation

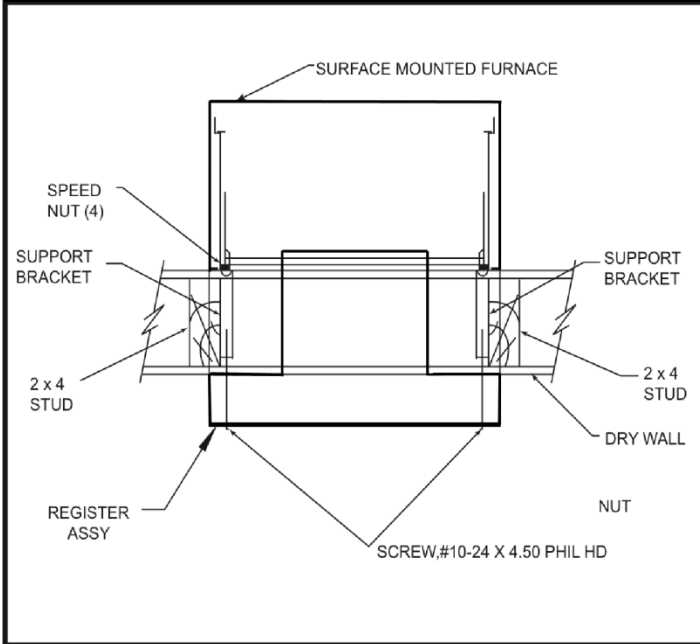
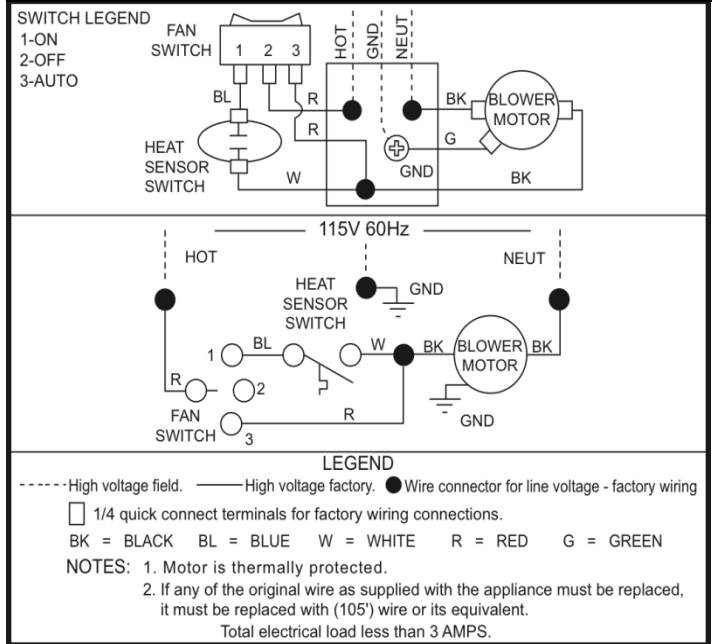
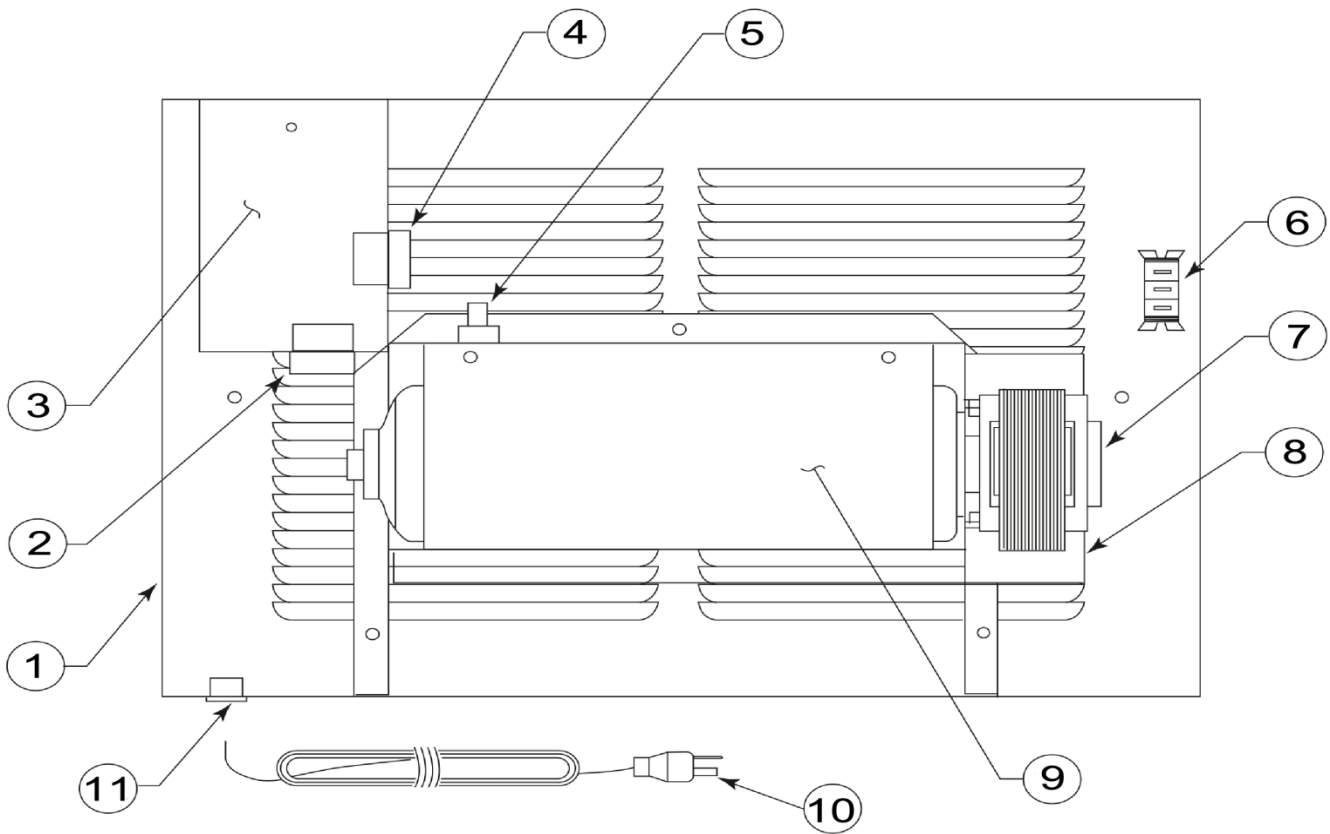

FIGURE F - Wiring



Motorized Rear Outlet Replacement Parts

Motorized Rear Outlet – Models 6919 and 6920



Motorized Rear Outlet Replacement Parts

Motorized Rear Outlet Replacement Parts (continued)

Motorized Rear Outlet Replacement Parts List – Models 6919 and 6920

| Ref. No. | Description | Part No. | |
|----------|--------------------------|----------|---------|
| | | 6919 | 6920 |
| 1 | Register Assembly | 9B269 | PB285 |
| 2 | Strain Relief Bushing | P500185 | P500185 |
| 3 | J-Box Cover | 9A427 | 9A427 |
| 4 | Strain Relief Bushing | P603108 | P603108 |
| 5 | Heat Sensor Switch | P323079 | P323079 |
| 6 | Fan Switch | P323080 | P323080 |
| 7 | Motor and Blower | P323076 | P323076 |
| 8 | Motor cover | 9A432 | PA462 |
| 9 | Motor Housing Back Plate | 9B266 | 9B284 |
| 10 | Cord and Plug | P323081 | P323081 |
| 11 | Bushing | P323084 | P323084 |

Use only manufacturer's authorized parts.

NOTE: Nuts, bolts, screws, and washers are standard hardware items and may be purchased locally.

Furnace Replacement Parts

Control Assembly – 250, 350, and 500 Series

CONTROL ASSEMBLY FOR 250 AND 350 SERIES MODELS

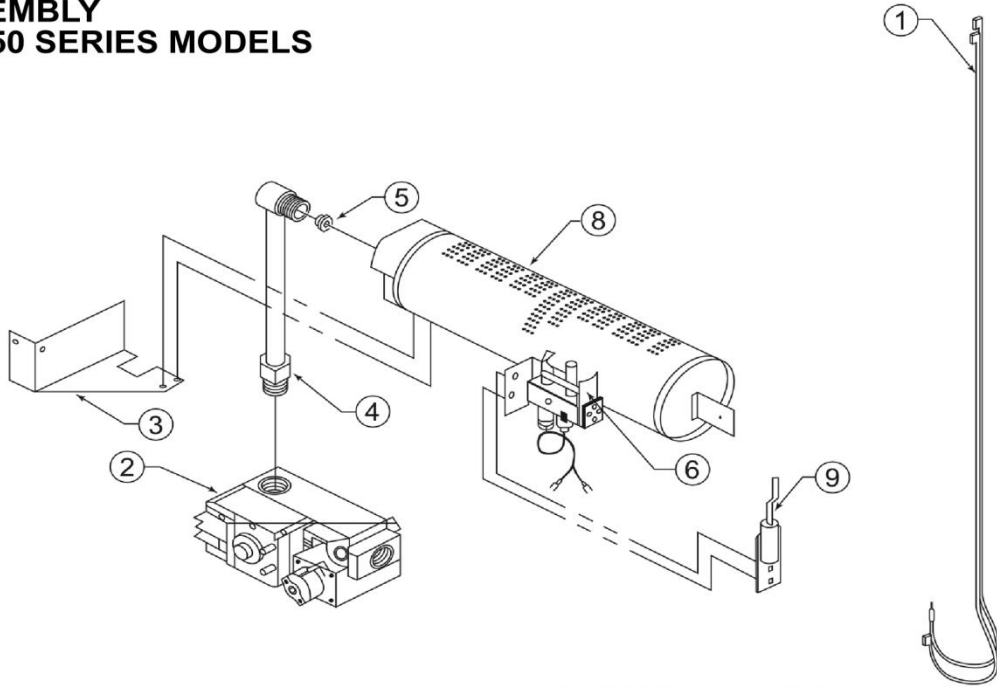

USE ONLY MANUFACTURER'S
AUTHORIZED PARTS
SEE PARTS LIST

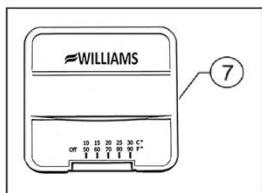

CONTROL ASSEMBLY FOR 500 SERIES MODELS

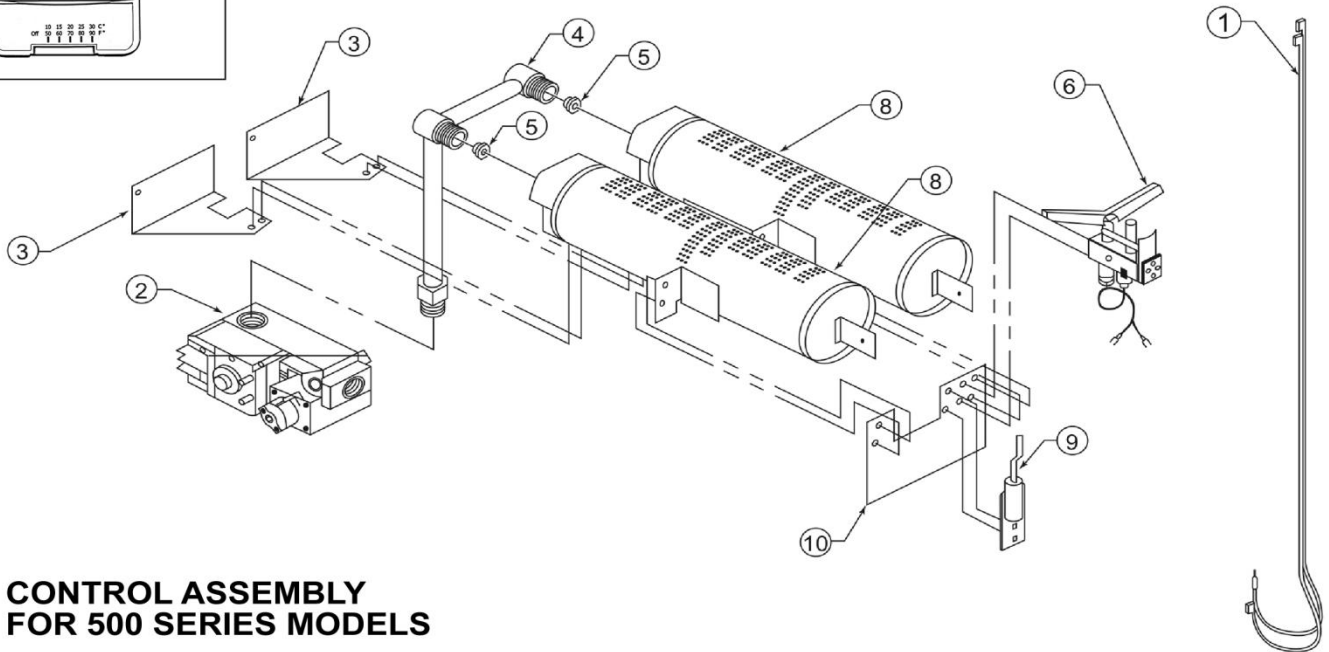

NOTE: Nuts, bolts, screws, and washers are standard hardware items and may be purchased locally.

Furnace Replacement Parts

Furnace Replacement Parts (continued)

Cabinet and Body Parts - 250 and 350 Series

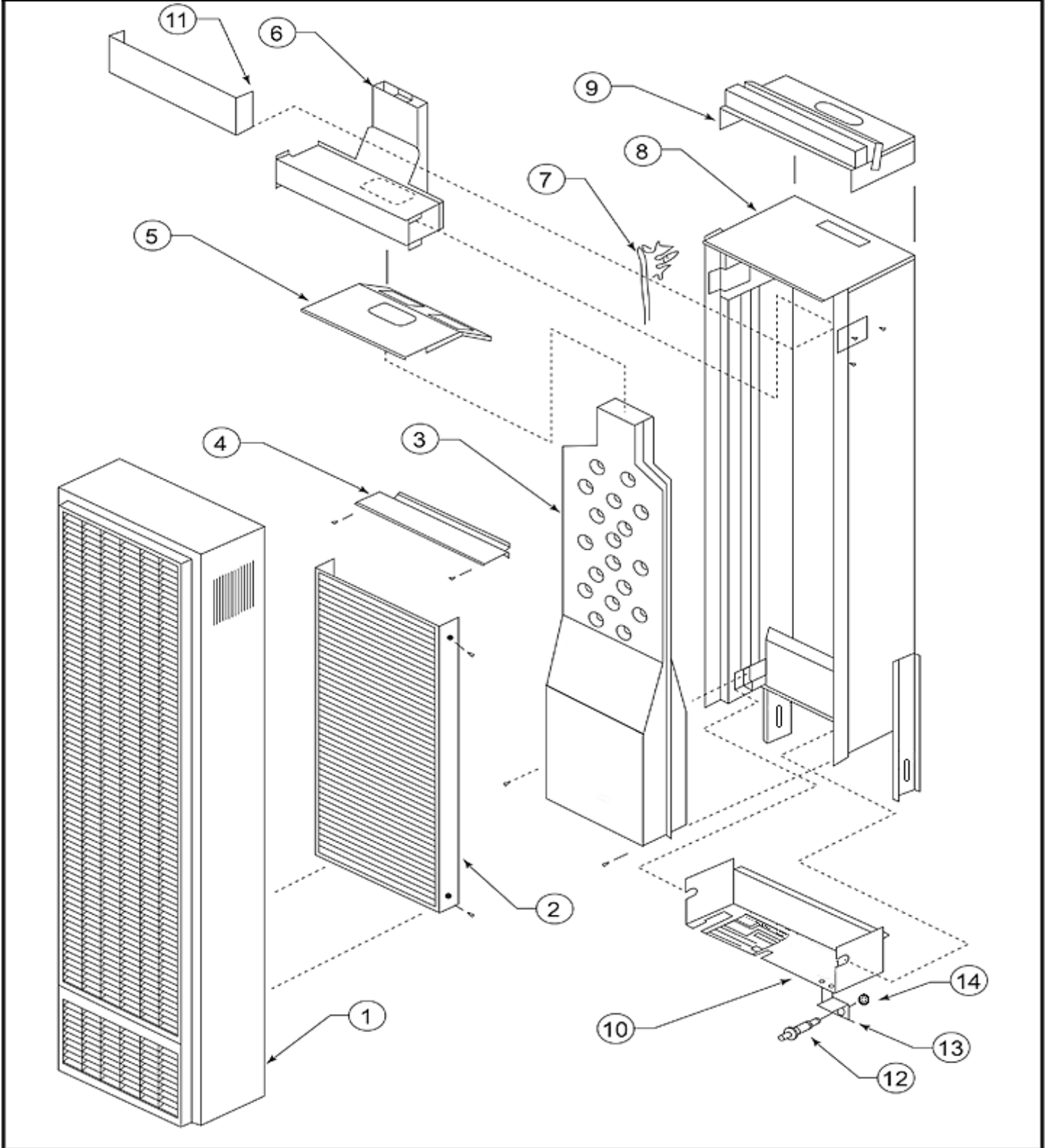

Furnace Replacement Parts

Furnace Replacement Parts (continued)

Cabinet and Body Parts – 500 Series

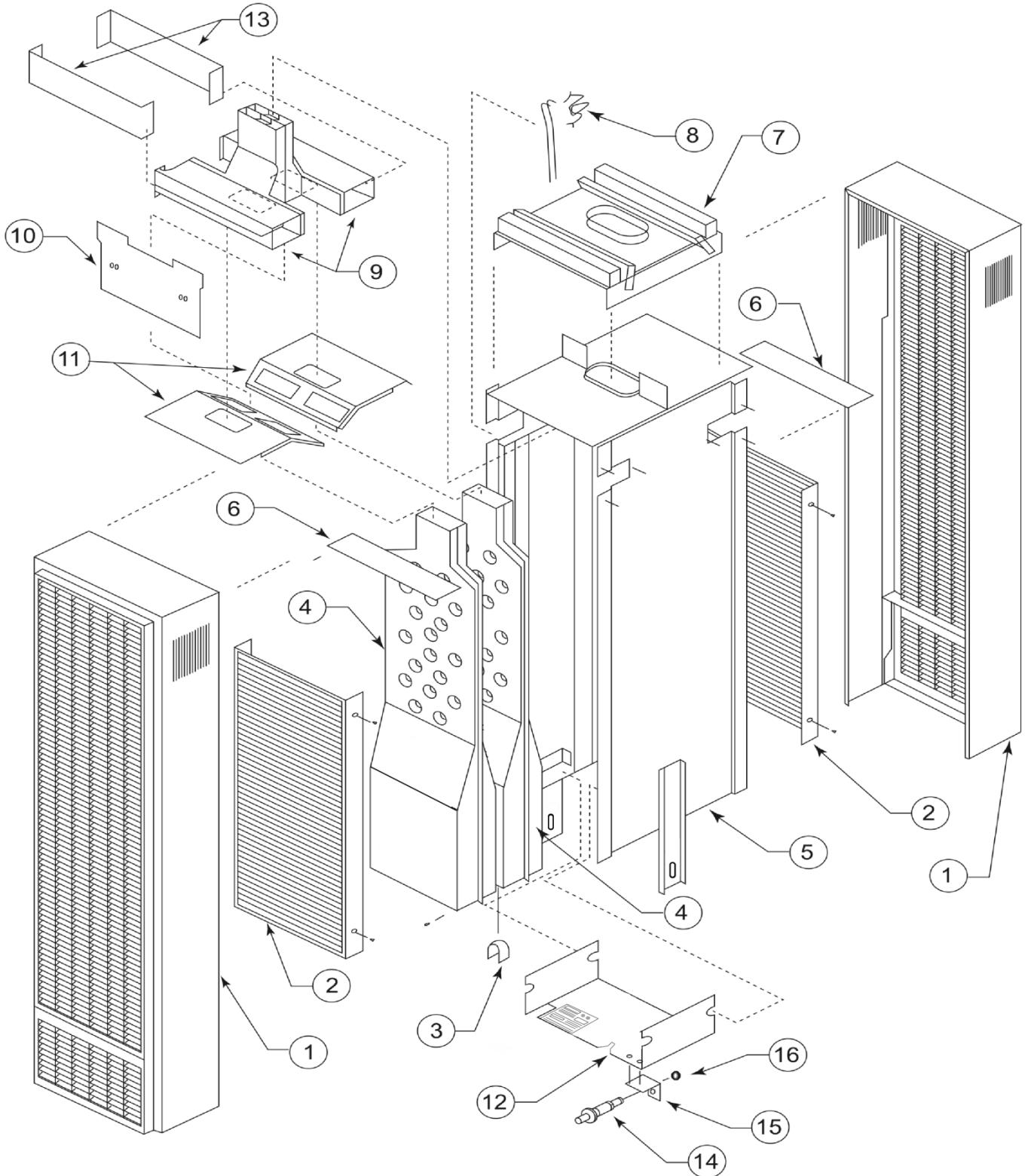

Furnace Replacement Parts

Furnace Replacement Parts (continued)

Control Assembly – 250, 350 & 500 Series

| REF. NO. | DESCRIPTION | 2509621 | 2509622 | 3509621 | 3509622 | 5009621 | 5009622 |
|----------|--|---------|---------|---------|---------|---------|---------|
| | | 2539621 | 2539622 | 3539621 | 3539622 | 5039621 | 5039622 |
| | | 2559621 | 2559622 | 3559621 | 3559622 | 5059621 | 5059622 |
| | | | | | | | |
| 1 | Wire Assembly (2 Required for 500 Series) | P321836 | P321836 | P321836 | P321836 | P321836 | P321836 |
| 2 | Valve | P322660 | P323011 | P322660 | P323011 | P322660 | P323011 |
| 3 | Front Burner Bracket | 9B234 | 9B234 | 9B234 | 9B234 | 9B243 | 9B243 |
| 4 | Manifold | P323660 | P323660 | P323660 | P323660 | P323661 | P323661 |
| 5 | Burner Orifice (2 Required for 500 Series) | P090554 | P090543 | P090554 | P090538 | P090554 | P090544 |
| 6 | Pilot/Generator Assembly | P501618 | P501617 | P501618 | P501617 | P322397 | P322396 |
| 7 | Thermostat | P322016 | P322016 | P322016 | P322016 | P322016 | P322016 |
| 8 | Burner (2 Required for 500 Series) | P323648 | P323648 | P323648 | P323648 | P323648 | P323648 |
| 9 | Electrode | P322276 | P322276 | P322276 | P322276 | P322155 | P322155 |
| 10 | Pilot Mounting Plate | - | - | - | - | 9A409 | 9A409 |

Cabinet and Body Parts - 250 & 350 Series

| REF. NO. | DESCRIPTION | 2509621 | 2509622 | 3509621 | 3509622 |
|----------|---------------------------|---------|---------|---------|---------|
| | | 2539621 | 2539622 | 3539621 | 3539622 |
| | | 2559621 | 2559622 | 3559621 | 3559622 |
| | | | | | |
| 1 | Face Panel | 4915 | 4915 | 4915 | 4915 |
| 2 | Front Heat Shield | 9C155 | 9C155 | 9C155 | 9C155 |
| 3 | Combustion Chamber | 6912 | 6912 | 6913 | 6913 |
| 4 | Deflector | 9B199 | 9B199 | 9B199 | 9B199 |
| 5 | Inner Shield Top | 9C153 | 9C153 | 9C153 | 9C153 |
| 6 | Draft Hood | 9C165 | 9C165 | 9C165 | 9C165 |
| 7 | Vent Limit Switch | P321826 | P321826 | P322055 | P322055 |
| 8 | Shield Assembly | 9C209 | 9C209 | 9C209 | 9C209 |
| 9 | Header | 5902 | 5902 | 5902 | 5902 |
| 10 | Burner Pan | 9B237 | 9B237 | 9B237 | 9B237 |
| 11 | Heat Deflector | 9A440 | 9A440 | 9A440 | 9A440 |
| 12 | Manual Spark Igniter | P285500 | P285500 | P285500 | P285500 |
| 13 | Igniter Bracket | 7A189 | 7A189 | 7A189 | 7A189 |
| 14 | Pal Nut | P285501 | P285501 | P285501 | P285501 |
| ** | Header - Insulation | P310000 | P310000 | P310000 | P310000 |
| ** | Parts Bag | 9A288-1 | 9A288-1 | 9A228-1 | 9A228-1 |
| ** | Knob | P332606 | P332606 | P332606 | P332606 |
| ** | Vent Limit Switch Bracket | P322074 | P322074 | P332074 | P332074 |

** Not Shown

Furnace Replacement Parts

Furnace Replacement Parts (continued)

Cabinet and Body Parts – 500 Series

| REF. NO. | DESCRIPTION | 5009621 | 5009622 |
|----------|---------------------------------|---------|---------|
| | | 5039621 | 5039622 |
| | | 5059621 | 5059622 |
| 1 | Face Panel (2 Required) | 4915 | 4915 |
| 2 | Front Heat Shield (2 Required) | 9C155 | 9C155 |
| 3 | Carryover Shell | 9A321-1 | 9A321-1 |
| 4 | Combustion Chamber (2 Required) | 6914 | 6914 |
| 5 | Shield Assembly | 9C211 | 9C211 |
| 6 | Deflector (2 Required) | 9B199 | 9B199 |
| 7 | Header | 5901 | 5901 |
| 8 | Vent Limit Switch | P321826 | P321826 |
| 9 | Draft Hood (2 Required) | 9C170 | 9C170 |
| 10 | Non-Vision Shield | 9C157 | 9C157 |
| 11 | Inner Shield Top (2 Required) | 9C158 | 9C158 |
| 12 | Burner Pan | 9B244 | 9B244 |
| 13 | Blower Heat Deflector | 9A440 | 9A440 |
| 14 | Manual Spark Igniter | P285500 | P285500 |
| 15 | Igniter Bracket | 7A189 | 7A189 |
| 16 | Pal Nut | P285501 | P285501 |
| ** | Header – Insulation | P310000 | P310000 |
| ** | Parts Bag | 9A288-1 | 9A288-1 |
| ** | Knob | P332606 | P332606 |
| ** | Vent Limit Switch Bracket | P322074 | P322074 |

** Not Shown

Troubleshooting Your Furnace

| SYMPTOM | POSSIBLE CAUSE(S) | CORRECTIVE ACTION |
|--|---|--|
| 1. Pilot will not stay lit after following lighting instructions. | <ul style="list-style-type: none"> a. Generator producing insufficient millivolts. b. Loose or dirty generator connections at gas valve. c. Generator defective. d. Grounded thermostat wire. e. Defective gas valve. | <ul style="list-style-type: none"> a. Check pilot flame. It must impinge on the generator. b. Clean and/or tighten generator connections at valve. c. Check generator with millivolt meter. Take reading at generator terminals of the valve with the valve placed in "Pilot" position. Disconnect the thermostat wires. The millivolt reading should be 450 millivolts or more. d. Remove thermostat wires from valve terminals. If pilot now stays lit, trace thermostat wiring circuit for a ground. May be grounded to furnace, gas supply, nails or staples. e. Replace gas valve after above is verified. |
| 2. No gas to the main burner. | <ul style="list-style-type: none"> a. Gas valve not turned to the "ON" position after lighting pilot. b. Thermostat not tuned to a position calling for heat. c. Plugged furnace orifice. d. Improper wired or broken thermostat wires. Defective thermostat. e. Pilot generator may not be generating sufficient millivolts to open valve. f. Defective valve. g. Vent safety switch tripped. | <ul style="list-style-type: none"> a. Turn gas valve knob to the "ON." b. Set thermostat to a position calling for heat. c. Check—clean or replace. d. Check connections at valve terminals. If valve operates, check thermostat wires. e. See 1a and 1c above. f. Replace gas valve after above is verified. g. Check and reset. |
| 3. Furnace operates but turns off before room temperature is attained. | <ul style="list-style-type: none"> a. Thermostat location. b. Defective thermostat. | <ul style="list-style-type: none"> a. Check thermostat location. It should not be in the path of warm air discharge from furnace, near a lamp or above a T.V. or stereo unit. b. Check thermostat calibration or replace. |
| 4. Furnace not producing sufficient heat. | <ul style="list-style-type: none"> a. Furnace may be too small for space being heated. b. Furnace not burning at full rate. | <ul style="list-style-type: none"> a. Check heat sizing calculations. b. Check for low gas pressure at gas valve. It should be 4 inches water column for natural gas; 10-inches water column for L.P.G. Check for blocked burner orifices. |
| 5. Furnace operates but will not shut off when room temperature is attained. | <ul style="list-style-type: none"> a. Thermostat wiring defective. b. Thermostat location. c. Defective thermostat. d. Valve stuck open. | <ul style="list-style-type: none"> a. Thermostat lead wires may be shorted together, caused by a nail or staple. Check by removing thermostat leads from valve terminals. b. Check thermostat location. If on an outside wall, or there is a hole in the wall behind the thermostat, cold air may be coming in contact with the thermostat. Relocate. c. Check thermostat calibration; verify thermostat temperature reading; or replace. d. Replace valve. |

Troubleshooting Your Furnace

Troubleshooting Your Furnace (continued)

| SYMPTOM | POSSIBLE CAUSE(S) | CORRECTIVE ACTION |
|----------------------------------|---|---|
| 6. Pilot outage. | <ul style="list-style-type: none"> a. Pilot flame may be low or blowing (high). b. Drafts or drafty areas. | <ul style="list-style-type: none"> a. Adjust pilot flame. Pilot orifice may be plugged (check for spider webs or other material). b. Check for doorway and high movement areas. |
| 7. Noisy blower. | <ul style="list-style-type: none"> a. Housing rattling. b. Blower dirty. c. Blower wheel bent. | <ul style="list-style-type: none"> a. Tighten blower screws. b. Clean blower wheel. c. Straighten or replace. |
| 8. Blower does not run. | <ul style="list-style-type: none"> a. Fan switch not set. | <ul style="list-style-type: none"> a. Select fan speed. |
| 9. Main burner will not stay on. | <ul style="list-style-type: none"> a. Blockage in vent pipe. b. Vent too short. c. Restriction in vent system caused by offsets. d. Incorrect vent pipe. e. Loose connections on the vent safety wiring harness. | <ul style="list-style-type: none"> a. Check vent pipe for blockage, such as bird nests, twigs, leaves, etc. Check that the vent cap is properly installed, and not placed too far down on the vent pipe. Cap must be the same manufacturer as the vent. b. The vent should terminate a minimum of 12 feet above the floor plate. The top of the vent must be at least 2 feet above any obstacle within a 10 foot radius, including the roof. c. All type "B" vents shall extend in a vertical direction with offsets not exceeding 45 degrees. Any angle greater than 45 degrees from vertical is considered horizontal. Any offsets used should be a minimum of 2-feet above the draft hood or as far away as possible to allow venting to begin before any restriction is encountered. The use of too many offsets may also prevent proper venting. d. Use listed B/W type vent pipe. DO NOT use transite or any other type of ceramic pipe for venting. DO NOT use single wall vent pipe. When venting into a masonry chimney, the chimney must be properly lined and sized for this gas furnace. The use of type "B" or flexible chimney liner is recommended. e. Check the connection on both the switch and the gas valve. Tighten if necessary. |
| 10. Abnormal operation. | <ul style="list-style-type: none"> a. Delayed ignition. Pilot flame may be too low. b. Expansion noise, ticking. c. Combustible gas spillage. d. Excessive flame roll-out. e. Burner is over-fired. f. Yellow burner flame. g. Yellow pilot flame. h. Expansion noise | <ul style="list-style-type: none"> a. Adjust pilot flame. Refer to "How to Care for Your Furnace" section in this manual. b. Check installation. Casing may be distorted by being fastened to an uneven opening or jammed under the header. A restricted vent may create expansion noise. Refer to "Vent Installation" section in this manual. c. Check vent system for a blocked flue, excessive down draft (wind) or negative pressure in room caused by a ventilating fan or a fire in a fireplace. d. Furnace is possibly overrated, check for high gas pressure at gas valve. (See 4B). e. Check the manifold gas pressure. Check the rate, this appliance is manufactured for elevations up to 4,500 feet. It must be derated for operation above 4,500 feet. f. Check burner for obstructions. Install new burner and pilot orifices. g. Remove pilot orifice, check and clean. h. DO NOT elevate the furnace off the floor unless supported by the free standing accessory. Never shear the legs. If replacing the furnace, bring the vent pipe to the header. DO NOT raise the furnace to the vent pipe. Legs must be flat on the floor plate, never one in front of the other. |

Hints and Information

Service Hints

If your furnace fails to work correctly, you may avoid the inconvenience and cost of a service call by checking the troubleshooting section on pages 38 and 39 before you call for service.

WARNING: If the information in this manual is not followed exactly, a fire or explosion may result causing property damage, personal injury or loss of life.

DO NOT store or use gasoline or other flammable vapors and liquids in the vicinity or this or any other appliance.

WHAT TO DO IF YOU SMELL GAS

- Open all of the windows.
- Do not try to light any appliance.
- Do not touch any electrical switch.
- Do not use any phone or cell phone in your building.
- Extinguish any open flame.
- Immediately call your gas supplier from a neighbor's phone. If you cannot reach your gas supplier, call the fire department.

Installation and service must be performed by a qualified installer, service agency or the gas supplier.

How to Order Repair Parts

When ordering repair parts, always give the following information:

1. MODEL NUMBER
2. MFG. DATE CODE
3. PART NUMBER
4. PART DESCRIPTION

All parts listed herein may be ordered from your equipment supplier. The Model Number of your Williams wall furnace will be found on the nameplate near gas valve, inside control compartment.



Williams Furnace Company • 250 West Laurel Street, Colton, CA 92324
(909) 825-0993 • FAX: (909) 824-8009 • www.wfc-fc.com

Manufactured in the U.S.A. • Established 1916



P322085 - APRIL 2012
ALL RIGHTS RESERVED